

United States District Court
Northern District of California

1
2
3
4
5
6
7
8
9
10
11
12
13
14
15
16
17
18
19
20
21
22
23
24
25
26
27
28

UNITED STATES DISTRICT COURT
NORTHERN DISTRICT OF CALIFORNIA

AUTOMATED PACKAGING SYSTEMS,
INC.,

Plaintiff,

v.

FREE FLOW PACKAGING
INTERNATIONAL, INC.,

Defendant.

Case No. [18-cv-00356-EMC](#)

CLAIM CONSTRUCTION ORDER

Docket No. 91, 92

[Contains Color Images]

This patent dispute relates to the air-filled plastic pouches that are placed in packages to fill empty space and protect merchandise. In the parlance of the patents at issue, such pouches are called “dunnage” and the plastic used to form them are called “webs.” Plaintiff Automated Package Systems, Inc. (“APS”) owns several patents for the design of plastic webs used to form dunnage units and the associated filling processes. APS sells a line of pouches called EZ-Tear Pillows that practice the patents.

APS’s patents fall into two families: the “Variable Perforation” or “Lerner” patents (‘191 and ‘288 patents) and the “Gap-Forming” or “Wehrmann” patents (‘220, ‘439, ‘994, and ‘459 patents). Broadly speaking, the “Variable Perforation” patents are distinguished by the use of perforations that are shorter on one end of the web but progressively longer toward the other end; the variability facilitates easy separation of the pouches after inflation without the need for a knife. The “Gap-Forming” patents serve the same purpose of easy separation, but rather than perforations, these patents are distinguished by a gap that forms between pouches upon inflation, enabling a worker to insert a hand to separate them.

Defendant Free-Flow Packaging International, Inc. (“FPI”) also sells lines of pouches

1 called Cell-O Green Air, Power Pak'r, Pro Pak'r, and Mini Pak'r cushions. APS accuses FPI's
2 product lines of infringing its patents.

3 The parties seek construction of 8 groups of terms, mostly at FPI's insistence.¹ FPI
4 contends three of the terms are indefinite. The Court construes the terms below.

5 I. LEGAL STANDARD

6 The construction of the terms in a patent claim is a question of law to be determined by the
7 Court. *See Markman v. Westview Instruments, Inc.*, 52 F.3d 967, 979 (Fed. Cir. 1995) (en banc),
8 *aff'd*, 517 U.S. 370 (1996). "[T]he interpretation to be given a term can only be determined and
9 confirmed with a full understanding of what the inventors actually invented and intended to
10 envelop with the claim." *Phillips v. AWH Corp.*, 415 F.3d 1303, 1316 (Fed. Cir. 2005) (citation
11 and quotation omitted). The "correct construction" will "stay[] true to the claim language and
12 most naturally aligns with the patent's description of the invention." *Id.* Not every claim term
13 must be construed, but "[w]hen the parties present a fundamental dispute regarding the scope of a
14 claim term, it is the court's duty to resolve it." *O2 Micro Int'l Ltd. v. Beyond Innovation Tech.*
15 *Co.*, 521 F.3d 1351, 1362 (Fed. Cir. 2008).

16 Claim construction proceeds according to important principles of interpretation. First, "the
17 claims of a patent define the invention," *Innova/Pure Water, Inc. v. Safari Water Filtration Sys.,*
18 *Inc.*, 381 F.3d 1111, 1115 (Fed. Cir. 2004). The words of a claim are generally given their
19 "ordinary and customary meaning," which is the "meaning that the term would have to a person of
20 ordinary skill in the art in question at the time of the invention." *Phillips*, 415 F.3d at 1312-13.
21 "The inquiry into how a person of ordinary skill in the art understands a claim term provides an
22 objective baseline from which to begin claim interpretation." *Id.* at 1313. Such a person "read[s]
23 the claim term not only in the context of the particular claim in which the disputed term appears,
24

25 ¹ Two terms that were originally selected by the parties have since been dropped. The first,
26 "closely spaced such that sides of successive pouches are lightly tacked together for [facile]
27 separation," was mooted when APS elected not to pursue infringement of the only claims in which
28 the term appeared ('191 patent claims 6 and 10, and '288 patent claims 5 and 9). See Docket No.
184 (APS's preliminary election of asserted claims). The second, "opposite edge," was withdrawn
by FPI with the Court's leave in favor of the newly added term, "large perforations," for which the
Court received supplemental briefing. See Docket Nos. 212 and 213.

1 but in the context of the entire patent, including the specification.” *Id.*

2 “In some cases, the ordinary meaning of claim language as understood by a person of skill
3 in the art may be readily apparent even to lay judges, and claim construction in such cases
4 involves little more than the application of the widely accepted meaning of commonly understood
5 words.” *Id.* at 1314. In other instances, however, claim language requires interpretation. In
6 construing claim language, the court looks to “those sources available to the public that show what
7 a person of skill in the art would have understood disputed claim language to mean,” including
8 “the words of the claims themselves, the remainder of the specification, the prosecution history,
9 and extrinsic evidence concerning relevant scientific principles, the meaning of technical terms,
10 and the state of the art.” *Id.* (quotations and citations omitted).

11 “[T]he claims themselves provide substantial guidance as to the meaning of particular
12 claim terms.” *Phillips*, 415 F.3d at 1314. The “context in which a term is used in the asserted
13 claim,” “[o]ther claims of the patent in question, both asserted and unasserted,” and “[d]ifferences
14 among claims” are all instructive. *Id.* “The claims, of course, do not stand alone” and instead
15 “must be read in view of the specification,” which is “[u]sually ... dispositive” and “the single best
16 guide to the meaning of a disputed term.” *Id.* at 1315.

17 Courts “normally do not interpret claim terms in a way that excludes disclosed examples in
18 the specification.” *Verizon Servs. Corp. v. Vonage Holdings Corp.*, 503 F.3d 1295, 1305 (Fed.
19 Cir. 2007). However, in general, “limitations from the specification are not to be read into the
20 claims.” *Comark Commc'ns, Inc. v. Harris Corp.*, 156 F.3d 1182, 1186 (Fed. Cir. 1998). That is
21 because “the purposes of the specification are to teach and enable those of skill in the art to make
22 and use the invention and to provide a best mode for doing so.” *Phillips*, 415 F.3d at 1323. The
23 effect and force of specifications varies. “[U]pon reading the specification in that context, it will
24 become clear whether the patentee is setting out specific examples of the invention to accomplish
25 those goals, or whether the patentee instead intends for the claims and the embodiments in the
26 specifications to be strictly coextensive.” *Id.*

27 In addition to consulting the specification, “the court should also consider the patent’s
28 prosecution history.” *Markman*, 52 F.3d at 980 (citing *Graham v. John Deere Co.*, 383 U.S. 1, 33

1 contrast, in the instant patent infringement litigation, the Court must construe the terms of the
2 claim in accordance with a different standard – claim terms are “generally given their ordinary and
3 customary meaning,” which is “the meaning that the term would have to a person of ordinary skill
4 in the art in question at the time of the invention, i.e., as of the effective filing date of the patent
5 application.” *Phillips v. AWH Corp.*, 415 F.3d 1303, 1312-13 (Fed. Cir. 2005). *See also PPC*
6 *Broadband, Inc. v. Corning Optical Commc’ns RF, LLC*, 815 F.3d 747, 756 (Fed. Cir. 2016)
7 (discussing the differences between the “broadest reasonable construction” standard applied in
8 IPR and claim construction under *Phillips*). Because of these material differences, FPI’s failure to
9 advance a construction or argue indefiniteness in IPR proceedings is explainable and thus not
10 probative to *Markman* claim construction. *See, e.g., GoPro, Inc. v. C&A Mktg., Inc.*, No. 16-cv-
11 03590, 2017 WL 3131449-JST, at *5 n.4 (N.D. Cal. Jul. 24, 2017) (agreeing that “arguments in
12 [a] petition[] for *inter partes* review . . . that the claims required no construction do not constitute
13 an admission for purposes of the claim construction in the district court litigation” because the
14 PTAB “applies a different standard . . . than this Court”); *JDS Techs., Inc. v. Avigilon USA Corp.*,
15 No. 15-cv-10385, 2017 WL 4248855, at *6 (E.D. Mich. Jul. 25, 2017) (holding that arguments in
16 IPR submissions are not relevant to claim construction because “the USPTO’s broadest reasonable
17 construction standard of claim construction has limited significance in the context of patent
18 infringement, which is governed by the more comprehensive scrutiny and principles required by
19 *Phillips* and its progeny”); *Fontem Ventures, B.V. v. NJOY, Inc.*, No. 14-cv-1645, 2015 WL
20 12766460, at *11 (C.D. Cal. Jan. 29, 2015) (refraining from constructing term based on IPR
21 submission because “the [IPR] and *Phillips* standards differ significantly”).

22 The Court now proceeds to construe the disputed claim terms.

23 A. “edge”

24 The term “edge” is used in both the Variable Perforation and Gap-Forming patent families.
25 *See* ‘191 [claims 1-3, 7, 8, 12], 288 [claim 1, 2, 6, 7, 11, 12], ‘220 [claim 1, 2], ‘439 [claim 1, 2, 6-
26 10, 14-20], ‘994 [claim 1], ‘459 [claim 1, 3]. APS advances a construction of “edge” to mean the
27 “line or area farthest from the center.” In contrast, FPI argues no construction of the term is
28 necessary, but if the Court proceeds, the plain meaning of the term is “[t]he line at which a film

1 surface terminates.” Because there is a material dispute between the parties whether an “edge” is
 2 only a line or whether it also may include an area, the Court construes the claim term. *O2 Micro*,
 3 521 F.3d at 1362.

4 In these patents, the term “edge” is used to describe, spatially, where the top and bottom
 5 layers of the web connect, where the transverse seals extend, and where the longitudinal lines of
 6 weakness reach. According to claim 1 of the ‘191 patent, for example:

7 1. A web for the manufacture of fluid filled units
 8 comprising:
 9 an elongate heat sealable, flattened plastic face and back
 10 layers including imperforate sections;
 11 the layers being imperforately joined together at a side **edge**
 12 by a selected one of a fold and a seal;
 13 the layers being joined by longitudinally spaced transverse
 14 seals, each transverse seal extends from the side **edge** and terminates
 15 in a spaced relationship with a fill edge of the layers;
 16 transverse lines of weakness extending from the side **edge** to
 17 the fill **edge** in a longitudinal direction of the seals that allow
 18 adjacent pouches to be separated;
 19 the side **edge** and traverse seals and lines of weakness
 20 together delineating a string of pouches with each pouch having two
 21 imperforate sections, three imperforate sides and a centrally located
 22 fill opening at its fourth side and,
 23 the transverse lines of weakness being defined by spaced
 24 perforations extending through both layers with the perforations
 25 nearest to the fill edge of the layers being shorter in length than the
 26 lengths of other perforations that are spaced further from the fill
 27 **edge** and extend toward the side **edge**.

28 ‘191 Patent, col. 6:42-64 (emphasis added).

19 On its face, the claim language is ambiguous with respect to whether an “edge” can
 20 constitute only a line or can also be an area. However, the specification and the accompanying
 21 schematics consistently show that an “edge” is more reasonably understood as a “line.” The
 22 following schematics are highlighted according to the corresponding specification language to
 23 demonstrate this point.²

24
 25
 26
 27
 28 ² These schematics are originally sourced from the patents in question, but the highlighted versions were presented by FPI during the claim construction hearing.

United States District Court
Northern District of California

1
2
3
4
5
6
7
8
9
10
11
12
13
14
15
16
17
18
19
20
21
22
23
24
25
26
27
28

A plurality of transverse seal pairs 34 are provided. As best seen in FIGS. 5-7, each transverse seal extends from an associated side edge 32 toward a longitudinally extending pair of lines of weakness 35. The longitudinal lines of weakness 35

'191 Patent at 3:35-46

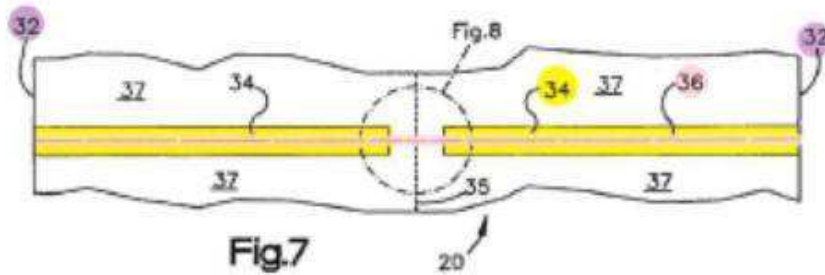
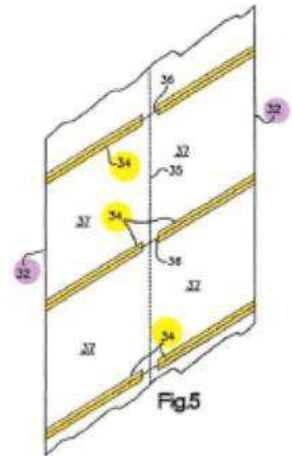

In these Figures 5 and 7 of the Variable Perforation patents ('191 and '288) purple side edges [32] are illustrated as lines. Similarly, every edge [20] and [18] in the Gap Forming patents ('220, '439, '994, and '459) is also illustrated as a line, as demonstrated by the purple and turquoise highlights in Figures 1, 2, 4, 5, 6, 7A, 7B, and 9 below:

16. Generally, each transverse seal 22 extends from the opposite edge 20 to within a short distance of the inflation edge 18.

'220 Patent at 3:24-25

24, 26. In the embodiment illustrated by FIG. 5, pairs 30 of transverse seals 22' extend from the opposite edge 20 to within a short distance of the inflation edge 18. Each of the

'220 Patent at 4:65-67

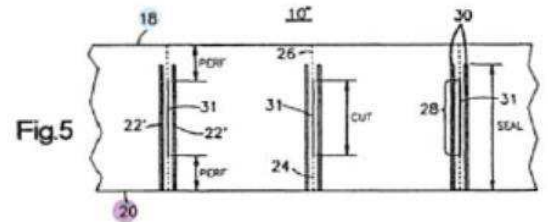
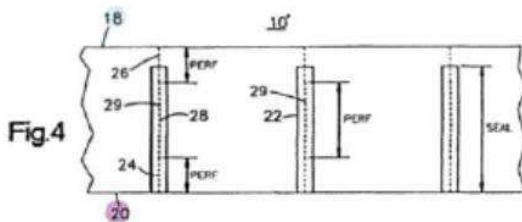

United States District Court
Northern District of California

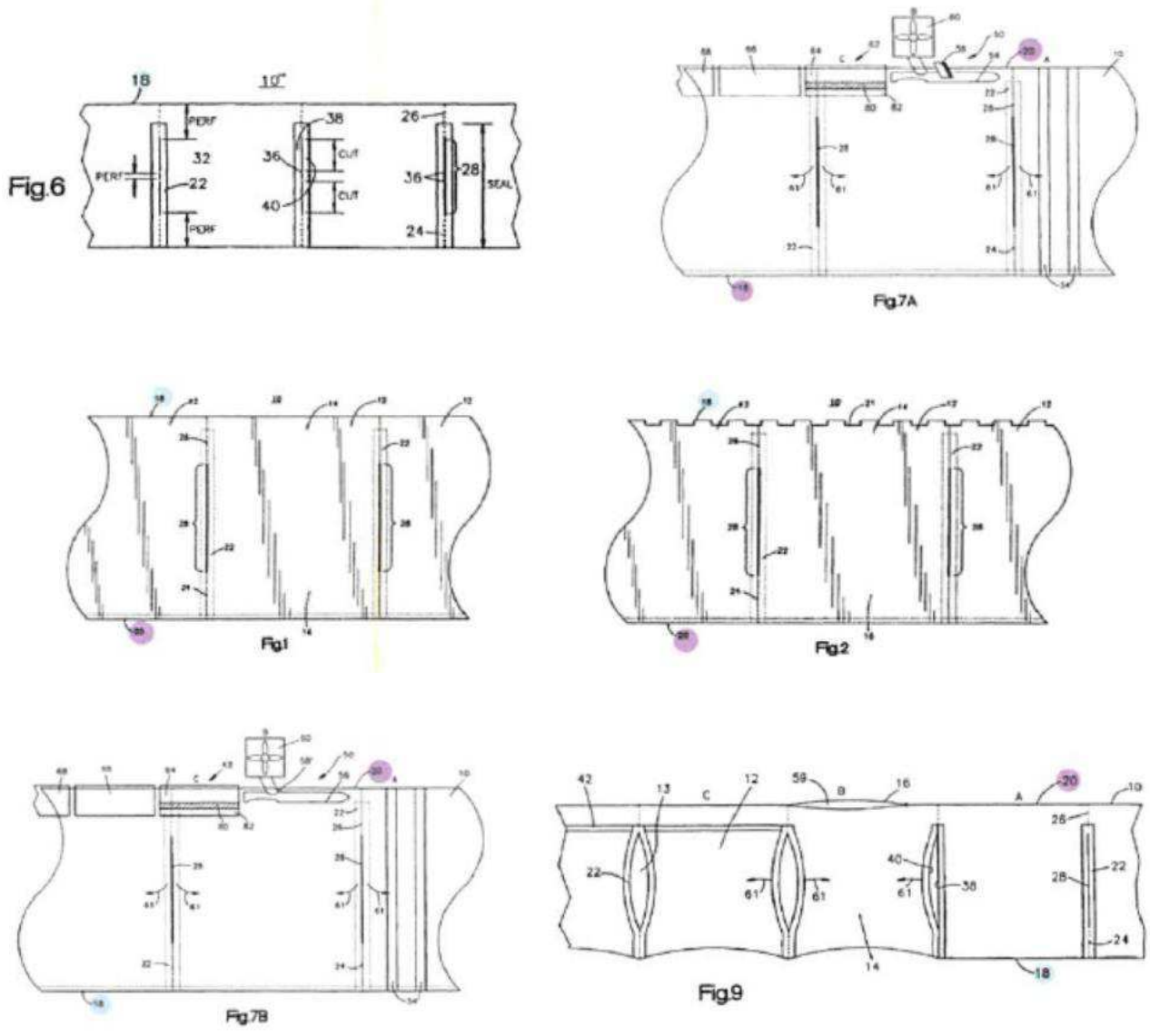

1
2
3
4
5
6
7
8
9
10
11
12
13
14
15
16
17
18
19
20
21
22
23
24
25
26
27
28

Arguing otherwise, APS cites only one piece of intrinsic support for its construction of the term “edge” as including an “area.” In particular, the specification for both patent families states that “[e]ach of the side edges is a selected one of *a fold or a seal* such that the superposed layers are hermetically connected along the side edges [32].” ‘191 Patent at 3:39-42; *see also* ‘220 patent at 3:9. APS contends that a seal must have an area and that, because an edge can consist of a seal, the edge too must have area. Although a seal must have area, even then, the edge can be a line; the seal is “along” a side edge. At best, this point of the specification is ambiguous. In any event, FPI presents credible evidence that, in the context of this patent, a person with ordinary skill

1 in the art would still understand the term “edge” to refer to the particular “line” where the seal
 2 terminates—not the whole area of the seal. In particular, the Wehrmann patents illustrate an
 3 example of an edge formed by a seal. Yet the specification still distinguishes between the edge
 4 [20] (illustrated as a line) and the area of the seal (the space between the edge and the dotted line,
 5 highlighted in red):

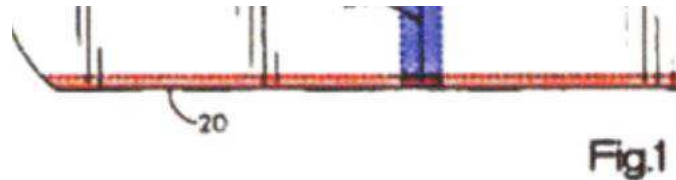

10 In addition, the specification of the Wehrmann patents states that “each transverse seal [22]
 11 extends from the opposite edge [20] to within a short distance of the inflation edge [18].” ‘220
 12 Patent at 3:20-21. Yet as illustrated in the magnified figure below, the transverse seal [22] (shaded
 13 in blue) extends from the line at which the surface terminates. If APS’s interpretation that an
 14 “edge” means an “area” were correct, one would expect the transverse seal [22] to be depicted to
 15 start from the dotted line indicating the end of the area of the seal (at the top of the shaded red
 16 area), not the line where the surface terminates.

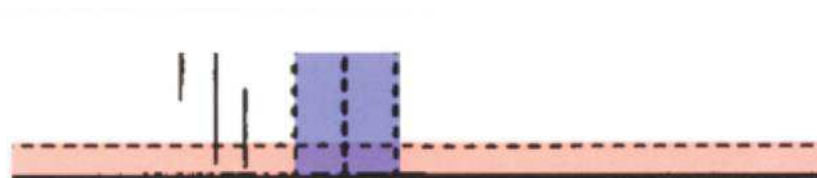

21 This interpretation is confirmed by the fact that, when the patent refers to something other
 22 than a seal that reaches the surface’s outermost limit, it uses different language: it states that the
 23 transverse seal [22] extends to “within a short distance of the inflation edge.” Sure enough,
 24 “within a short distance of the inflation edge” is depicted in Figures 1-2 of the Wehrmann patents
 25 as stopping short of the line at which the surface terminates. In the shaded figure below, this is
 26 illustrated as the gap between the blue shaded transverse seal [22] and the inflation edge [18].
 27 If an “edge” were an “area,” then the specification could simply state “to the inflation edge” rather
 28 than “within a short distance of the inflation edge.” Thus, the specifications support the

1 interpretation that the “edge” is the “line where the surface terminates.”

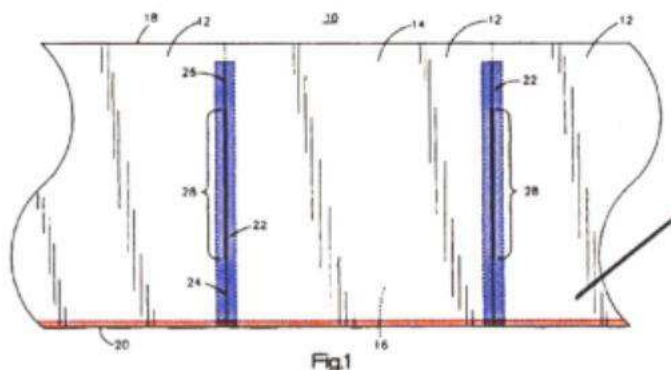

9 The strong and univocal intrinsic support for FPI’s construction of an “edge” as a “line”
10 rather than an “area” is bolstered by the extrinsic evidence. In particular, APS cites common
11 dictionary definitions which define an edge as either a “line” or “area,”³ but the relevant technical
12 dictionary, the Glossary of Packaging Terms, confirms FPI’s narrower construction because it
13 defines edge as “[t]he line formed by the junction of two faces, or of the end and the body wall, of
14 a container or part. The rim of a cylindrical container or tub.” FPI Op. Br., Ex. L, at 73. The
15 technical dictionary carries more weight than APS’s common dictionaries. *See Transclean Corp.*
16 *v. Bridgewood Serv., Inc.*, 290 F.3d 1364, 1375 (Fed. Cir. 2002) (“[T]o the extent there is a
17 difference between the common and technical meanings of the terms . . . a technical dictionary is
18 [] a better source to inform the meaning of the term to a skilled artisan.”). Furthermore, FPI’s
19 expert, Dr. Schueneman, explains that a skilled artisan would understand an “edge” to be a line
20 even when formed by a seal because of the manner in which two-layered film is typically
21 manufactured. *See Schueneman Rebuttal Decl.* ¶¶ 17-18 (FPI Resp. Br., Ex. 2) (explaining that
22 sealing and folding are alternative methods to create a two-layered film which have no functional
23 difference but may differ in terms of procedural complexity and cost, but in either case, “the
24 critical feature that must be present to form the side is that the two layers of film must both

25
26
27
28

3 *See* APS Op. Br., Ex. G (freedictionary.com: defining “edge” as “The line or area farthest away from the middle”); Ex. H (Merriam Webster: defining “edge” as “the line where something begins or ends; also: the area adjoining such an edge.”); Ex. I (Webster’s: defining “edge” as “the line where an object or area begins or ends: BORDER . . . ; the narrow part adjacent to a border . . . ; a point near the beginning or the end”).

1 terminate and be connected together along a line”).

2 APS also points to a statement by the patent examiner in the prosecution history regarding
 3 another prior art patent, the “Perkins” patent. In rejecting certain claims, the patent examiner
 4 stated that transverse seals in the “Perkins” patent “extend[] from the side edge.” APS Op. Br.,
 5 Ex. Y, ‘191 Prosecution History, 1/31/2008 Office Action at 2; *id.*, Ex. Z, ‘288 Prosecution
 6 History, 2/4/2010 Office Action at 2. In the schematic from the Perkins patent, below, the seals
 7 [14] do not touch the very limit of the “side edge” [B], suggesting that the patent examiner
 8 possibly understood “side edge” in the Perkins patent to be an area. *See* APS Op. Br. at 8.

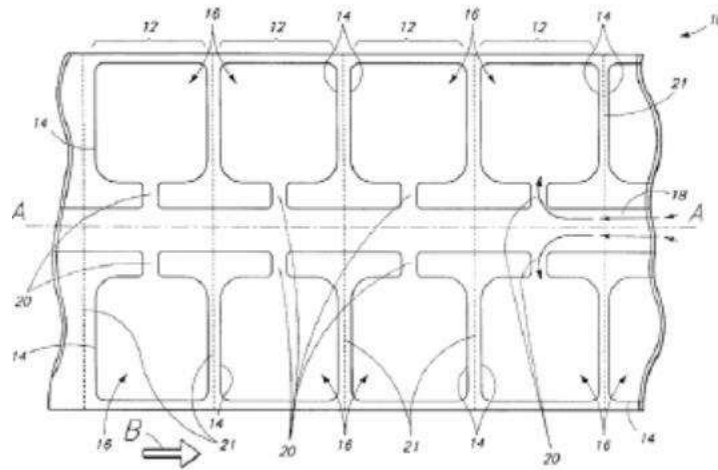

FIG. 1

9
 10
 11
 12
 13
 14
 15
 16
 17
 18 Although “[s]tatements about a claim term made by an examiner during prosecution of an
 19 application may be evidence of how one of skill in the art understood the term at the time the
 20 application was filed,” *Salazar v. Procter & Gamble Co.*, 414 F.3d 1342, 1347 (Fed. Cir. 2005), in
 21 this context the Court affords minimal weight to the patent examiner’s statement, because “[t]he
 22 USPTO’s broadest reasonable construction standard of claim construction has limited significance
 23 in the context of patent infringement, which is governed by the more comprehensive scrutiny and
 24 principles required by *Phillips* and its progeny.” *JDS Techs., Inc. v. Avigilon USA Corp.*, No. 15-
 25 cv-10385, 2017 WL 4248855, at *6 (E.D. Mich. Jul. 25, 2017). *See Cuozzo Speed Tech., LLC v.*
 26 *Lee*, 36 S.Ct. 2131, 2145 (2016) (“In an initial examination of an application for a patent the
 27 examiner gives the claim its broadest reasonable construction.”). Furthermore, the patent
 28

1 examiner’s statement was made in the context of the specific “Perkins” patent; it does not reflect
2 how a person skilled in the art would understand the meaning of “edge” in the context of the
3 Lerner and Wehrmann patents, particularly in light of the strong evidence in the claim
4 specifications indicating that an “edge” is only a “line.”

5 In sum, the intrinsic and extrinsic evidence strongly support FPI’s construction that “edge”
6 in the patents means the “line where the surface terminates.”

7 B. “fill edge,” “split edge,” “fill opening at [its/a] fourth side”

8 The parties also dispute whether the terms “fill edge,” “fill opening at [the] fourth side”
9 and “split edge” in the Lerner patents require construction. *See* ‘191 patent [cls. 1-3, 7, 8, 12];
10 ‘288 patent [cls. 1, 6, 7, 11, 12, 14].

11 Both the ‘191 and ‘288 patents describe the “fill edge” and “split edge” respectively in
12 relation to the “side edge.” For example, in the ‘191 patent, the web is formed from a top and
13 bottom layer which are “imperforately joined together at a side edge,” and then “each transverse
14 seal extends from the side edge and terminates in a spaced relationship with a fill edge of the
15 layers; transverse lines of weakness extending from the side edge to the fill edge in a longitudinal
16 direction of the seals that allow the adjacent pouches to be separated . . . and the transverse lines of
17 weakness being defined by spaced perforations extending through both layers with the
18 perforations nearest to the fill edge of the layers being shorter in length than the length of other
19 perforations that are spaced further from the fill edge and extend toward the side edge.” ‘191
20 patent at 6:42-64.

21 ///

22 ///

23 ///

24 ///

25 ///

26 ///

27 ///

28 ///

1 Similarly, the '288 patent, provides that: "the web is comprised of top and bottom letters
 2 "joined at a side edge," with "longitudinally spaced transverse seals . . . extending from the side
 3 edge toward but spaced from a split edge of the layers," with "longitudinally spaced transverse
 4 lines of weakness extending away from the side edge toward the split edge." '288 patent at 7:5-16
 5 (claim 7) (emphasis added). Visually, the split edge of the '288 patent is highlighted in yellow in
 6 the annotated Figure 6 below:

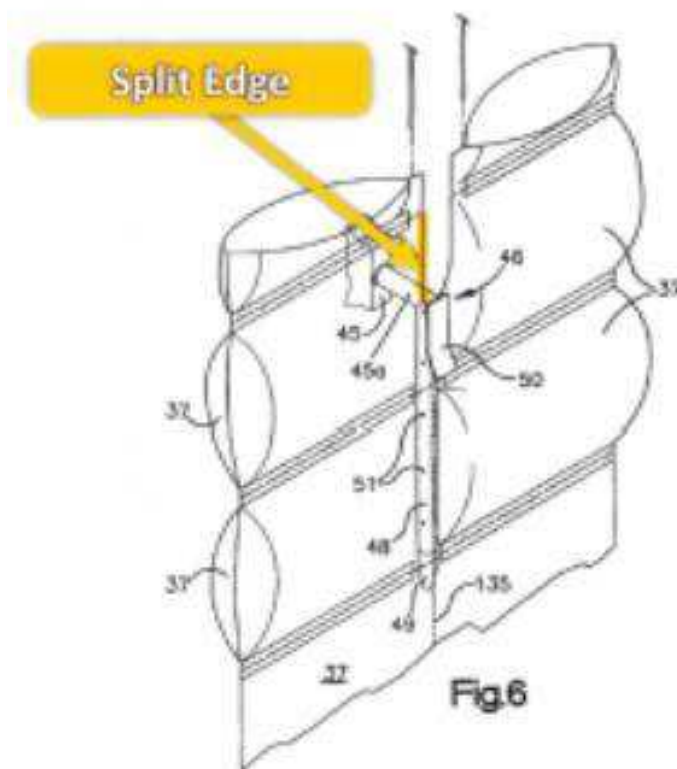

21 This "split edge" is alternatively referred to as the "fourth side," *i.e.*, the side of each pouch
 22 near the fill opening. *See* '288 Patent at 6:49-54 (claim 1) (describing a web where "the side edge
 23 and transverse seals together delineat[e] a string of pouches with each pouch having two
 24 imperforate sections, three imperforate sides and a fill opening at a fourth side," where the
 25 "transverse lines of weakness extend[] away from the fourth side toward the side edge").

26 APS argues these terms do not require construction, while FPI argues they should be
 27 defined as follows:
 28

- 1 • fill edge: the “edge located between the two oppositely oriented strings of
2 pouches through which each dunnage unit is filled” - ‘191 patent, claims 1-3, 7,
3 8, 12
- 4 • fill opening at [its/a] fourth side: “opening located on the edge located between
5 the two oppositely oriented strings of pouches through which each dunnage unit
6 is filled” ‘191 claim 1, ‘288 claims 1 and 12
- 7 • split edge: the “edge located between the two oppositely oriented strings of
8 pouches through which each dunnage unit is filled and which splits during the
9 inflation process” ‘288 patent, claims 6, 7, 11, 12, 14

10 The proposed constructions arise from a larger dispute about whether APS’s patent claims are
11 limited to a two-chain web of pouches, as FPS contends. Because the scope of the terms is
12 disputed, the Court will construe them. *O2 Micro*, 521 F.3d at 1362.

13 The intrinsic evidence overwhelmingly supports the notion that APS’s claim is limited to
14 webs with two strings of pouches. The patents state that “the side edge and transverse seals and
15 lines of weakness together delineat[e] a string of pouches with each pouch having two imperforate
16 sections, three imperforate sides and a *centrally located* fill opening at its fourth side.” ‘191
17 Patent at 6:55-58. As FPI argues, the term “centrally located” must be given meaning, and the
18 only sensible meaning is “centrally located” between two strings of pouches.

19 APS argues that “centrally located” does not refer to transverse centering (i.e., between
20 two strings of pouches) but rather longitudinal centering (i.e., between the two transverse seals
21 that form two sides of a single pouch). But that argument is not persuasive because it contradicts
22 the specification—as APS acknowledged at the hearing, the “fill openings” are depicted at several
23 points along the fill edge/fourth side, not simply a single point centered along the fill edge or
24 fourth side. *See* Marking 51 in Fig. 6 of the ‘288 patent above.

The specification confirms this interpretation of the claim term “centrally located.” It specifically explains that the nozzle through which the web is inflated must be dragged along the centered position between two strings of pouches:

dricial surfaces. In use, the nozzle is inserted into the novel web at a transversely centered position as the web is fed

generally conical, lead end portion 49. The nozzle 48 when in use extends into the web at a central location transversely speaking. The web transverse lines of weakness are spaced

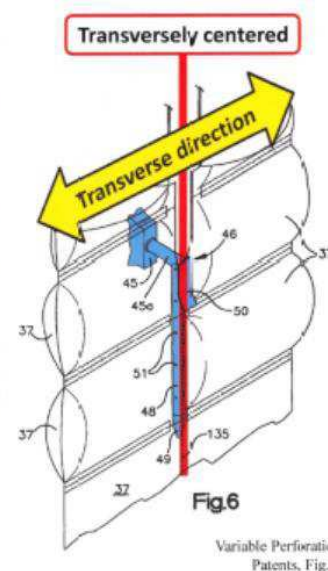

Indeed, the patents’ “summary of the invention” explains that “[t]he present invention is embodied in a plastic web” for which “web pouches are inflated and the web is separated into *two chains of inflated pouches* as the nozzle assembly separates the web along longitudinal lines of weakness.” ‘191 Patent at 1:59-2:18 (emphasis added). “When a patent . . . describes the features of the ‘present invention’ as a whole, this description limits the scope of the invention.” *GPNE Corp. v. Apple Inc.*, 830 F.3d 1365, 1371 (Fed. Cir. 2016). Elsewhere, the “present invention” is illustrated as a two-pouch web:

Similarly:

As we have suggested, one of the outstanding features of the invention is that the web closely surrounds and slides along the nozzle. The close surrounding is assured by the transverse seals being spaced a distance substantially equal to one half the circumference of the nozzle 48. Thus, the two web layers together delineate a nozzle receiving space which will closely surround an inserted nozzle. As the web advances

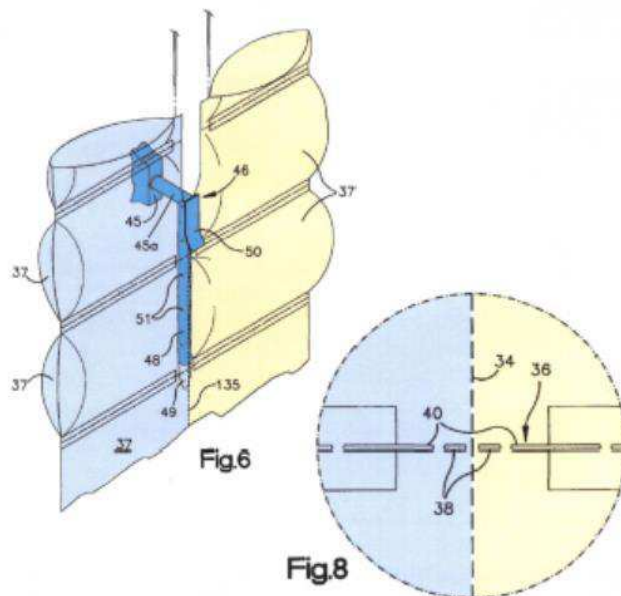

1
2
3
4
5
6
7
8
9
10
11
12
13
14
15
16
17
18
19
20
21
22
23
24
25
26
27
28

1 Indeed, the two chains of pouches are claimed as one of the invention’s benefits, because it
 2 permits “dunnage units [to be] produced at the rate of eight cubic feet per minute.” ‘191 Patent at
 3 2:30-31. *See Barnes & Noble, Inc. v. LSI Corp.*, No. C-11-2709 EMC, 2014 WL 1365422, at *22
 4 (N.D. Cal. Apr. 7, 2014) (“In construing claims, the problem the inventor was attempting to solve,
 5 as discerned from the specification and the prosecution history, is a relevant consideration.”).

6 In short, the “patent ‘repeatedly and consistently’ characterize[s]” the claim terms in
 7 relation to two strings of pouches, so “it is proper to construe the claim term[s] in accordance with
 8 that characterization.” *GPNE Corp.*, 830 F.3d at 1370. The following annotated figures from the
 9 patent specification, presented by FPI and highlighted in blue and yellow to signify the separate
 10 chains, confirm this consistent characterization:

11 **Two Chains**

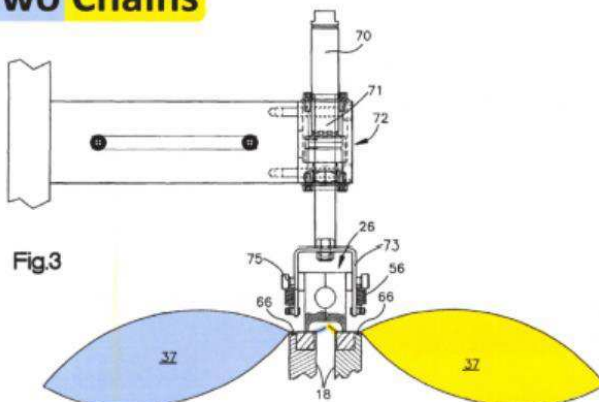

12 Fig.3

13 Variable Perforation Patents, Fig. 3

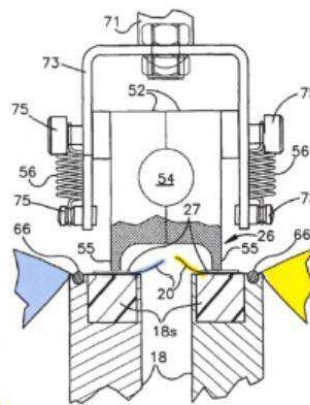

14 Fig.3A

15 Variable Perforation Patents, Fig. 3A

16 **Two Chains**

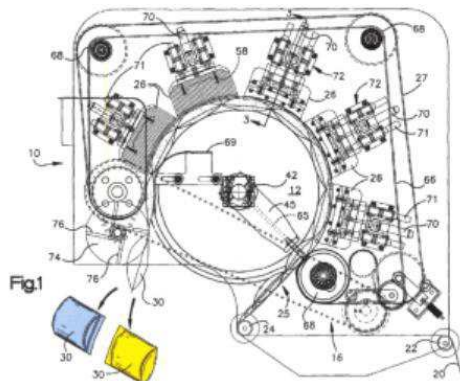

17 Fig.1

18 Variable Perforation Patents, Fig. 1

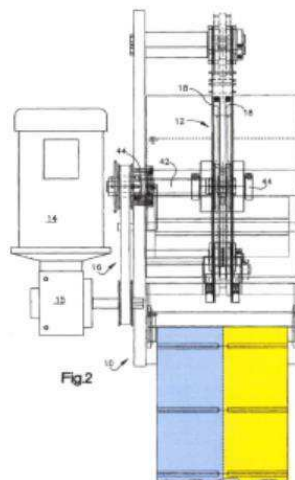

19 Fig.2

20 Variable Perforation Patents, Fig. 2

United States District Court
Northern District of California

1
2
3
4
5
6
7
8
9
10
11
12
13
14
15
16
17
18
19
20
21
22
23
24
25
26
27
28

Two Chains

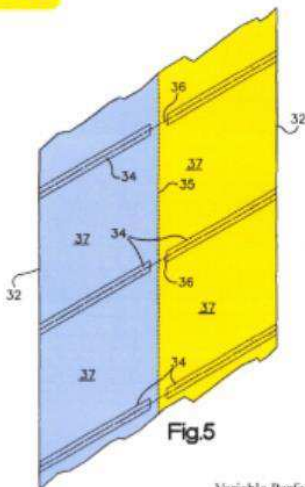

Fig.5

Variable Perforation Patents, Fig. 5

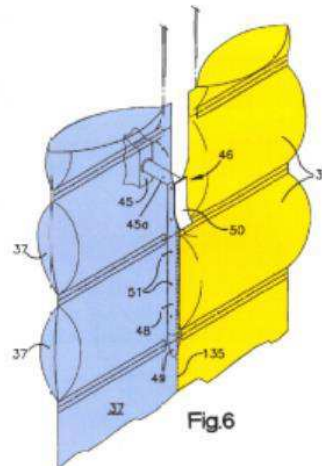

Fig.6

Variable Perforation Patents, Fig. 6

Two Chains

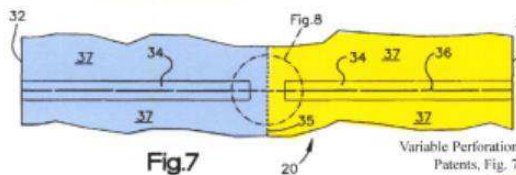

Fig.7

Variable Perforation Patents, Fig. 7

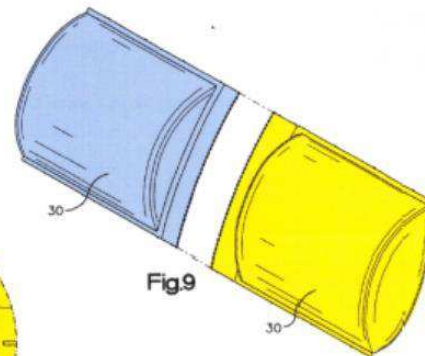

Fig.9

Variable Perforation Patents, Fig. 9

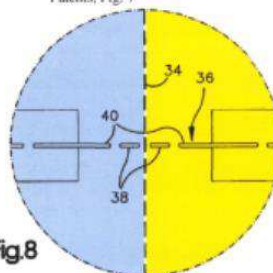

Fig.8

Variable Perforation Patents, Fig. 8

Two Chains

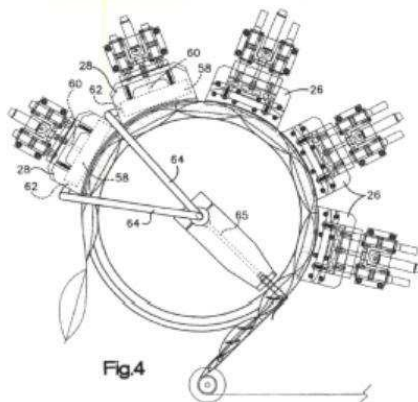

Fig.4

Variable Perforation Patents, Fig. 4

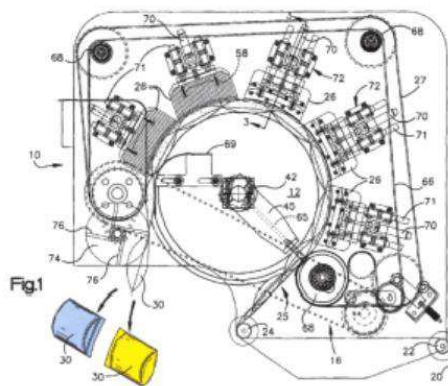

Fig.1

Variable Perforation Patents, Fig. 1

1 Similarly, the patent specification and abstract specifically describe the invention as
 2 claiming a web with two chains of pouches:

3
 4 form of uniform, small perforations. The transverse seal pairs
 34 together with the side edges 32 delineate two chains of
 centrally open side connected, inflatable pouches 37.
 '191 Patent at 3:51-53

5
 6 formed the fluid will be air. The web is then split by the nozzle
 support into two chains of side connected and fluid filled
 pouches respectively traveling along associated ones of the
 two paths of travel.
 '191 Patent at 6:11-14

7
 8 ing either the cylinders 70 or 70'. The web is then fed sequen-
 tially, and one at a time, under the heating shoes 26 and the
 cooling shoes 28. Since the web has been split by the nozzle
 support 55, there are in fact two parallel paths of travel each
 with an associated transport belt 27 and chain of side con-
 nected and inflated pouches.
 '191 Patent at 5:57-60

9
 10 of each seal in a longitudinal direction. The side edges, trans-
 verse seals and lines of weakness together delineating two
 oppositely oriented strings of pouches with each pouch hav-
 ing three imperforate sides and a centrally located fill opening
 at its fourth side. The transverse lines of weakness are spaced
 '191 Patent at Abstract

11
 12 pouch to be fluid filled. When the units being formed are
 dunnage, as the web passes over the nozzle, web pouches are
 inflated and the web is separated into two chains of inflated
 pouches as the nozzle assembly separates the web along
 longitudinal lines of weakness.
 '191 Patent at 2:14-18

13
 14 near but spaced from the longitudinal lines of weakness. The
 transverse seal pairs include transverse lines of weakness
 extending from one side edge to the other generally centrally
 of each seal in a longitudinal direction. The side edges, trans-
 '191 Patent at Abstract

15 In the face of this impressive and uniform intrinsic evidence, APS' argument against the
 16 "two string" limitation is based solely on the prosecution history of the '191 and 288 patents.
 17 Specifically, APS dropped an express reference to "two oppositely oriented strings of pouches"
 18 from the claim terms themselves. See APS Op. Br., Ex. S, '191 Pros. History, APS_000013-16,
 19 APS 000041-45; Ex. T, '288 Pros. History, APS_001373-1376, APS_001353-1359. According to
 20 APS, it is therefore improper to read the limitation back into the claim language. See *U.S.*
 21 *Telectronics, Inc.*, 857 F.2d 778, 783 (Fed. Cir. 1988) (where applicant unsuccessfully proposed a
 22 limiting amendment to overcome a prior art objection and then withdrew the amendment, it was
 23 improper to limit the claim according to the withdrawn amendment). APS, however, misconstrues
 24 the record. Although the explicit language was removed, the patent continued to refer to two
 25 oppositely oriented strings of pouches. As noted, the claim described the "fill opening" of the two
 26 strings of pouches as "centrally located" between the two side edges, and the only way for this
 27 language to be given meaning is to assume the claim was still limited to two strings of pouches.
 28 See FPI Resp. Br., Exs. 4-5 (redlines demonstrating that the "centrally located" language did not
 disappear when the "two strings" language was removed). Thus, the mere fact that the explicit

United States District Court
 Northern District of California

1 limitation was removed is insufficient to demonstrate that the claim was affirmatively broadened
2 where all the intrinsic evidence suggests otherwise. *Cf. Edwards Lifesciences LLC v. Cook Inc.*,
3 582 F.3d 1322, 1332-33 (Fed. Cir. 2009) (“Although, during prosecution, the inventors canceled
4 claims requiring ‘malleable wires’ and replaced them with claims requiring only ‘wires,’ they
5 conducted the prosecution as if the wires were required to be malleable.”). Other than its post-hoc
6 argument in this litigation, APS has not introduced any evidence from the prosecution history
7 evidencing that the purpose of the amendment was to broaden the claim.

8 APS also argues that the two strings of pouches interpretation is incorrect because claim 1
9 of the ‘191 Patent and claims 1 and 12 of the ‘288 Patent refer to the web as having “a string of
10 pouches.” *See* ‘191 Patent at 6:56 and ‘288 Patent at 6:49-50 and 8:9-10 (emphasis added). In
11 context, this part of the claim describes how “the side edge and transverse seals and lines of
12 weakness together delineat[e] a string of pouches with each pouch having two imperforate
13 sections, three imperforate sides, and a centrally located fill opening at its fourth side.” ‘191
14 Patent at 6:56. But this language does not imply the web must only have one string of pouches.
15 The use of the singular “a” does not defeat FPI’s construction that the patent claims two chains of
16 pouches; “a string of pouches” may easily describe the features of *each* string, and not necessarily
17 a reference to there being only a single string. *See KCJ Corp. v. Kinetic Concepts, Inc.*, 223 F.3d
18 1351, 1356 (Fed. Cir. 2000) (“Unless the claim is specific as to the number of elements, the article
19 ‘a’ receives a singular interpretation only in rare circumstances when the patentee evinces a clear
20 intent to so limit the article.”). The use of “a” does not overcome the other intrinsic evidence
21 strongly suggesting the invention is a two-string pouch.

22 APS also argues under the claim differentiation doctrine that FPI’s interpretation is at war
23 with the claim language because claim 8 of the ‘191 patent and claims 7 and 14 of the ‘288 patent
24 do not recite any “pouches,” even though claims 1 of the ‘191 and claims 1 and 12 of the ‘288 do.
25 *See Env'tl. Designs v. Union Oil Co. of Cal.*, 713 F.2d 693, 699 (Fed. Cir. 1983) (“It is improper
26 for courts to read into an independent claim a limitation explicitly set forth in another claim.”).
27 According to APS this means the inventors did not intend the web to be limited to any particular
28 arrangement of pouches. Claims 1 and 8 of the ‘191 and 1, 7, 12, and 14 of the ‘288 are all

1 independent claims, however, so the claim differentiation doctrine does not apply. *See Phillips*,
 2 415 F.3d at 1315 (“[T]he presence of a *dependent* claim that adds a particular limitation gives rise
 3 to a presumption that the limitation in question is not present in the *independent* claim.” (emphasis
 4 added)).

5 In any event, “[e]ven the presumption of different claim scope is overcome by a contrary
 6 construction dictated by the written description.” *World Class Tech. Corp. v. Ormco Corp.*, 769
 7 F.3d 1120, 1126 (Fed. Cir. 2014) (quotation and citation removed). Here, it is obvious that claims
 8 8 of the ‘191 and claims 7 and 14 of the ‘288 are webs that create pouches, even if that specific
 9 word is not used in every claim. Indeed, the formation of pouches is the purpose of the invention.
 10 *See, e.g.*, ‘191 Patent at 1:53-55 (background of invention stating “it would be desirable to provide
 11 an improved system for filling pouches with fluid to produce dunnage or liquid filled units at high
 12 rates of speed”).

13 Finally, APS argues that FPI’s definitions are tautological because they use the terms
 14 “filled” and “split” to define “split edge” and “fill edge.” This argument is unpersuasive because
 15 the dispute is not over the intrinsic meaning of the words “fill” and “split,” but rather, about which
 16 “edge” the adjectives describe. The dispute is about the location of the edges. It is therefore
 17 appropriate and logical for FPI’s construction to use those terms.

18 For these reasons, the Court adopts FPI’s construction of these terms:

Term	Construction
“fill edge”	“edge located between the two oppositely oriented strings of pouches through which each dunnage unit is filled”
“fill opening at [its/a] fourth side”	“opening located on the edge located between the two oppositely oriented strings of pouches through which each dunnage unit is filled”
“split edge”	“edge located between the two oppositely oriented strings of pouches through which each dunnage unit is filled and which splits during the inflation process”

1 C. “joined together,” “connected together,” and “sealed together” at an “edge”

2 The parties disagree about whether a family of terms including “joined together,”
3 “connected together,” and “sealed together” at an “edge” require construction. See ‘191 patent
4 [cls. 1, 8]; ‘288 patent [cls. 1, 7, 12]; ‘220 patent [cl. 1]; ‘439 patent [cls. 1, 6, 15-19]). These
5 terms are used in both patent families in the following contexts:

- 6
- 7 • “A web for the manufacture of fluid filled units comprising: an elongate heat
8 sealable, flattened plastic face and back layers including imperforate sections;
9 the **layers being imperforately joined together at a side edge** by a selected
10 one of a fold and a seal;” ‘191 patent at 6:42-47 [claim 1]; *see also* ‘288
11 patent at 6:41-46; 7:5-10; 7:33-38 [claims 1, 7, 12];
 - 12 • “A web for forming dunnage units, comprising: a first elongated layer; a second
13 elongated layer superposed over the first elongated layer, the first and second
14 layers **connected together at an inflation edge and an opposite edge**”
15 ‘220 patent at 7:35-39 [claim 1]; *see also* ‘439 patent at 7:38-44 [claim 1]
16 (describing two layers as “connected together at the opposite edges”); *id.*
17 [claims 6, 15, 16, 17, 18, stating layers “connected together at their inflation
18 edges” or “at their opposite edges”].

19 APS argues that the terms “connected together” and “joined together” do not require any
20 construction, but FPI proposes that they mean that “the layers meet and terminate at an edge of the
21 film.” The dispute is, essentially, whether the top and bottom layers of plastic are joined at the
22 edge itself or can be joined some distance from the edge. Because the scope of the terms is
23 disputed, the Court will construe them. The Court first notes that, as held above, edge means “the
24 line at which a film surface terminates.”

25 The intrinsic evidence consistently supports FPI’s construction. First and foremost, the
26 claim language specifically states that “the first and second layers [are] connected together *at* an
27 inflation edge and an opposite edge.” ‘220 Patent, Cl. 1 (emphasis added); *see also* ‘191 Patent,
28 Cl. 1 (stating the layers are “joined together *at* a side edge” (emphasis added)); ‘439 Patent, Cl. 8
(stating “the first elongated layer and the second elongated layer are sealed together *at* their
opposite edges” (emphasis added)). This language is straightforward.

Similarly, the patent specifications consistently describe the layers as being joined or
sealed “at” or “along” the edge of the film. See ‘191 Patent Abstract (the layers are “joined

1 together *along* spaced side edges” (emphasis added)); 191 Patent at 3:35-46 (the layers are
 2 “connected together *at* spaced side edges” and they are “hermetically connected *along* the side
 3 edges” (emphasis added)); ‘220 Patent at 2:30-33 (the layers “are connected by a frangible
 4 connection that extends *along* an inflation edge and a hermetic seal that extends *along* an opposite
 5 edge” (emphasis added)); ‘220 Patent at 3:6-18 (the layers are “connected together *along* spaced
 6 edges,” are connected “*along* the edges,” and there is a connection “*at* the opposite edge”
 7 (emphasis added)); ‘220 Patent at 5:58-62 (describing a “connection *at* the inflation edge”
 8 (emphasis added)); *see also* ‘191 Patent at 3:51-53 (the two chains of pouches are “side
 9 connected”); *id.* at 5:57-60 (same).

10 The figures accompanying the specifications corroborate this understanding that the
 11 connection between the layers occurs at the “edge,” *i.e.*, as construed herein, the line (not the area)
 12 at which the film surface terminates, as demonstrated below in the annotated figures presented by
 13 FPI:

Variable Perforation Patents

heat sealable plastic such as polyethylene. The web includes
 superposed top and bottom layers **connected together at
 spaced side edges 32.** Each of the side edges is a selected one
 ‘191 Patent at 3:38-40

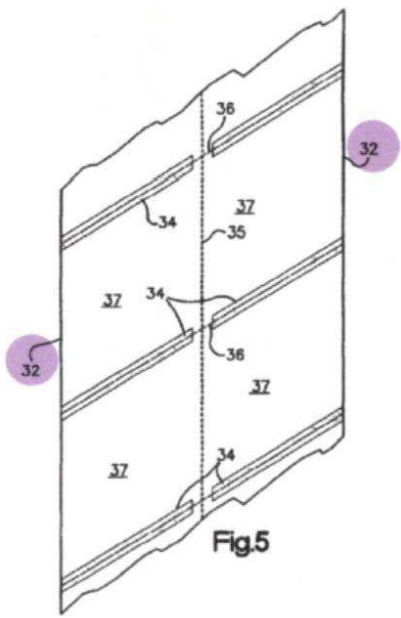

Gap Forming Patents

superposed over the first elongated layer. The first and second layers are connected by a frangible connection that extends along an inflation edge and a hermetic seal that extends along an opposite edge. The frangible connection at the inflation

'220 Patent at 2:30-33

layer of plastic 16. The layers are connected together along spaced edges, referred to as the inflation edge 18 and the opposite edge 20. In the example illustrated by FIG. 1, each edge 18, 20 is either a fold or a seal that connects the superposed layers 14, 16 along the edges 18, 20. The connection at the opposite edge 20 is illustrated as a hermetic seal and the connection at the inflation edge 18 is illustrated as a fold in FIG. 1. However, the fold and the seal could be reversed or both of the connections could be seals in the FIG. 1 embodiment. In the example illustrated by FIG. 2, the inflation edge 18 comprises a frangible connection 21 and the opposite edge 20 is a hermetic seal. The illustrated frangible connection 21 is a line of perforations. The size of the perforations is exag-

'220 Patent at 3:6-18

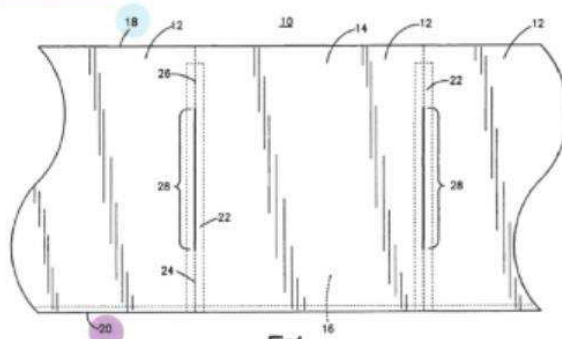

The connection of the layers 14, 16 at the inflation edge 18 can be any connection that is maintained between layers 14, 16 prior to the web 10 being processed to create dunnage units 12'. In the embodiment illustrated by FIG. 1, the connection is a fold. In the embodiment illustrated by FIG. 2, the connec-

'220 Patent at 5:58-62

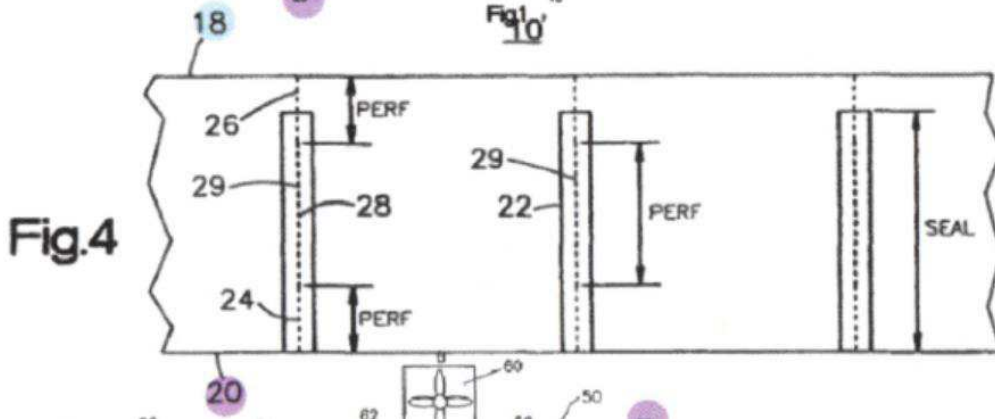
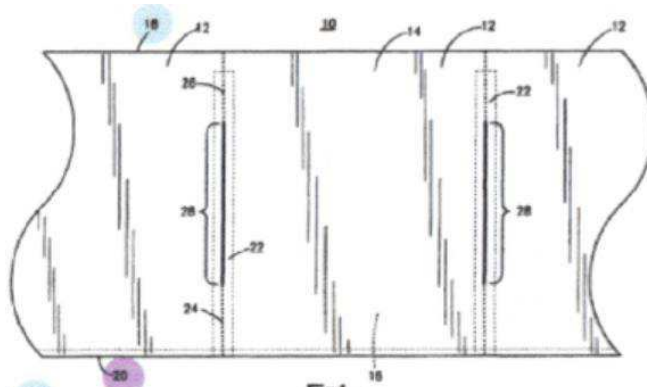

United States District Court
Northern District of California

1
2
3
4
5
6
7
8
9
10
11
12
13
14
15
16
17
18
19
20
21
22
23
24
25
26
27
28

United States District Court
Northern District of California

1
2
3
4
5
6
7
8
9
10
11
12
13
14
15
16
17
18
19
20
21
22
23
24
25
26
27
28

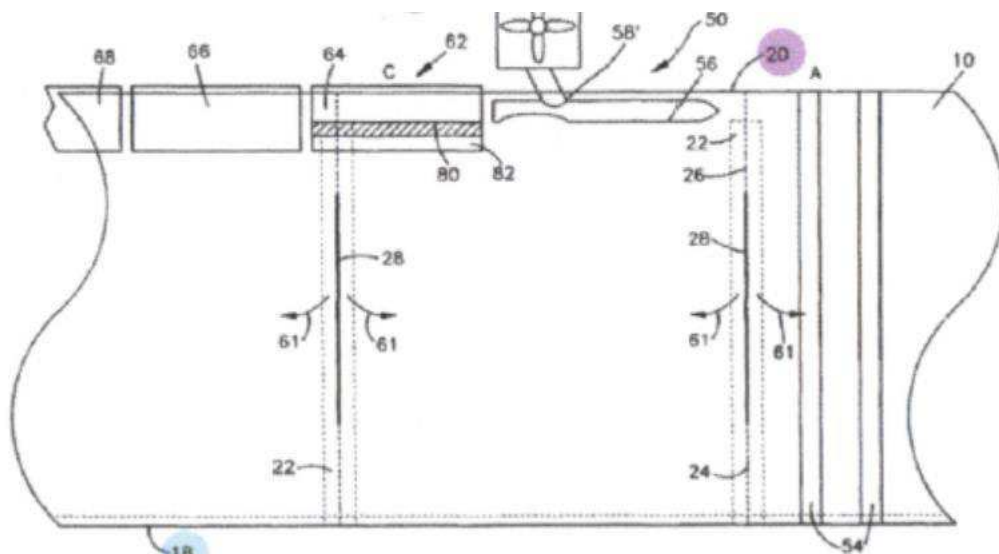

Fig.7B

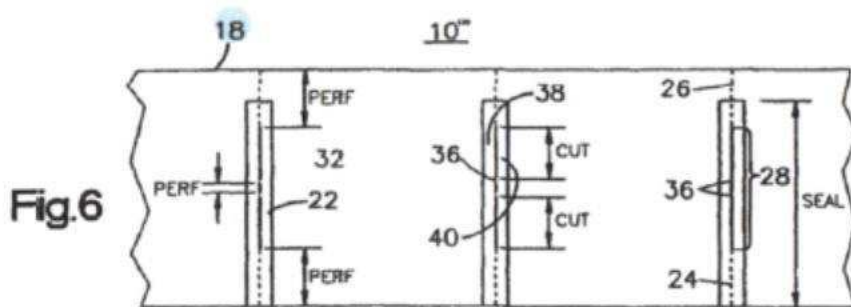

Fig.6

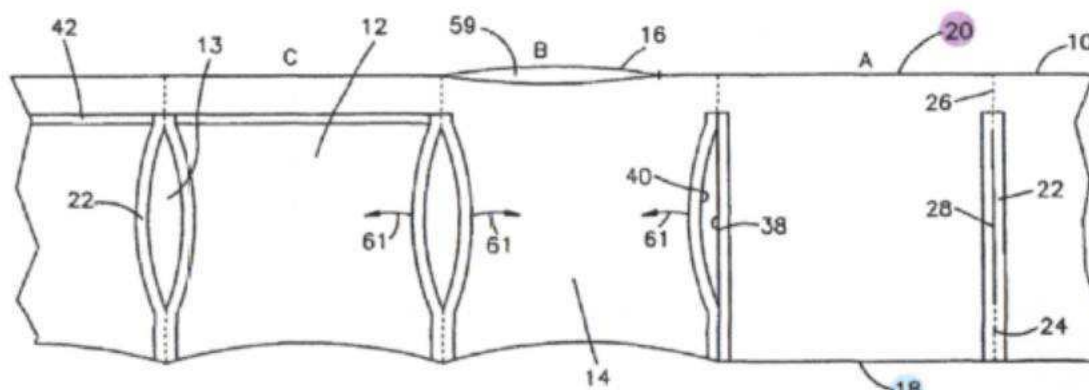
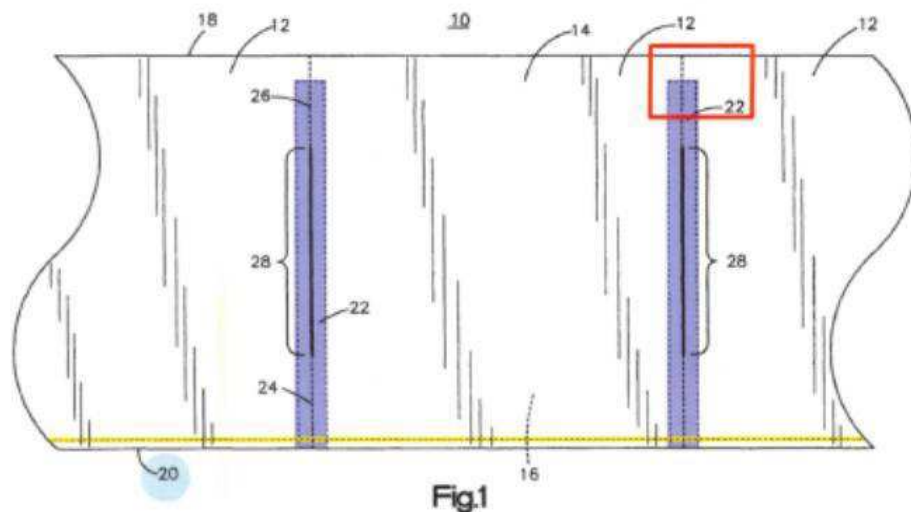

Fig.9

1 Nevertheless, APS argues that FPS’s interpretation would exclude a preferred embodiment
 2 depicted in Figures 1-2 and 7A-B of the Wehrmann patents. According to APS, these figures
 3 demonstrate an example of film material extending “beyond” where the transverse seal [22] and
 4 opposite side edge [20] meet according to the patent specification. In the figure below, APS
 5 would contend that the highlighted “purple” portion extending beyond the yellow highlighted
 6 “dashed” line disproves FPS’s argument.

7 **16. Generally, each transverse seal 22 extends from the oppo-**
 8 **site edge 20 to within a short distance of the inflation edge 18.**
 9 '220 Patent at 3:24-25



19 APS misrepresents the diagram and the claim language. APS erroneously claims the
 20 dotted line is the “opposite” edge. In fact, the yellow dotted line (which is not numbered in the
 21 figure but is parallel to and above the opposite side edge [20]) represents the limit of the seal
 22 connecting the top and bottom layers. The “opposite edge” according to the specification is line
 23 [20]. And, as the Court held above, an “edge” is a “line,” not an area. Therefore, this
 24 specification is entirely consistent with the construction that the layers are “joined together” at and
 25 along the “edge,” because the purple “transverse seal” [22] actually goes beyond the yellow-
 26 highlighted dotted line *all the way* to the “opposite edge” [20] where the film terminates. The
 27 following diagram (a magnified and annotated version of Figure 1) demonstrates the point:

16. Generally, each transverse seal 22 extends from the opposite edge 20 to within a short distance of the inflation edge 18.

'220 Patent at 3:24-25

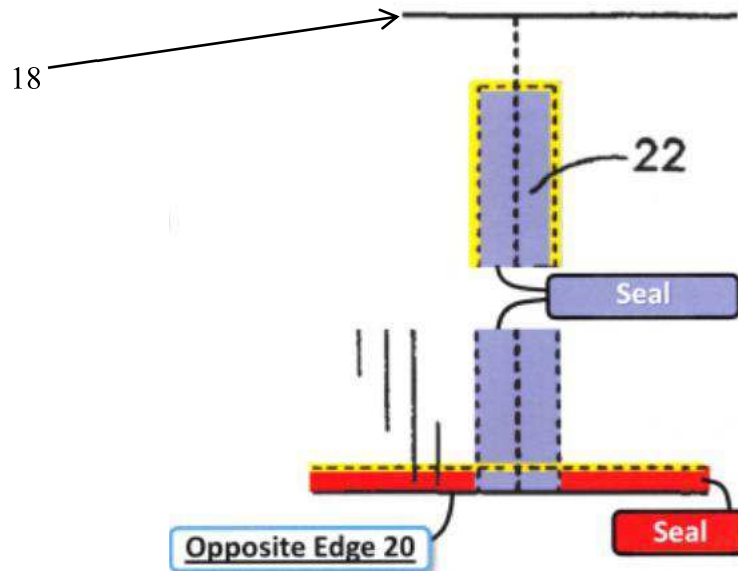

United States District Court
Northern District of California

For these reasons, APS' citation to *Omega Eng'g, Inc. v. Raytek Corp.*, 334 F.3d 1314, 1322-3 (Fed. Cir. 2003) for the proposition that the Court should not add a limitation where there is no basis to do so in the claim or patent specification is inapposite. Here, there is a clear basis from the patent claims consistently describing the connections occurring “at” the edges; from the specification language consistently stating that they occur “at” or “along” the edges; and from the diagrams in the specifications clearly demonstrating that the layers terminate where they are joined together at or along the edges. *See CVI/Beta Ventures, Inc. v. Tura LP*, 112 F.3d 1146, 1153 (Fed. Cir. 1997) (“[P]atent drawings are highly relevant in construing the . . . limitations of the claims.”). *Cf. Advanced Steel Recovery, LLC v. X-Body Equipment, Inc.*, 808 F.3d 1313, 1317 (Fed. Cir. 2015) (affirming district court’s narrow construction of “proximate end” to mean “the extreme or last part lengthwise” where “every figure that depicts the disputed connection shows the container packer piston-and-cylinder unit connected to the container packer at the container packer’s extreme edge” (emphasis added)).

Accordingly, the Court adopts FPI’s construction that the terms “connected together” and “sealed together” “at” an edge mean that “[t]he layers meet and begin” or “meet and terminate” at

1 those edges of the film.

2 D. “transverse seals” and “pouch defining seals”

3 The parties also dispute a family of terms describing “transverse seals” and “pouch
4 defining seals.” See ‘191 patent [cls. 1, 8]; ‘288 patent [cls. 1, 7, 12]; ‘220 patent [cl. 1]; ‘439
5 patent [cls. 1, 9, 20]; ‘994 patent [cl. 1]. These terms appear in several places throughout the
6 claims. See, e.g., ‘191 Patent at 6:46-51 (“the layers being joined by longitudinally spaced
7 transverse seals, *each* transverse seal extends from the side edge and terminates in a spaced
8 relationship with a fill edge of the layers” and “the side edge and transverse seals . . . together
9 delineating a string of pouches”); ‘288 patent at 6:47-52 (emphasis added); ‘220 patent at 7:40-44
10 (“a plurality of transverse seals extending from the opposite edge to within a first predetermined
11 distance from the inflation edge, wherein said opposite edge and said transverse seals form a
12 plurality of inflatable adjacent pouches”) (emphasis added); ‘439 patent at 7:45-49 (“a plurality of
13 transverse seals extending from the opposite edge to within a predetermined distance from the
14 inflation edge, wherein the connection at the opposite edges and said transverse seals form a
15 plurality of adjacent inflatable pouches”).

16 The crux of the dispute is whether the transverse seals are straight and separate (as FPI
17 contends) or whether curved, continuous seals (which run from one transverse seal on one side to
18 the transverse seal on the other side, including the seal forming the side edge) are covered by the
19 patents (as APS contends). Because the scope of the terms is disputed, the Court must construe
20 them. *O2 Micro*, 521 F.3d at 1362.

21 The intrinsic evidence does not support FPI’s proposed limitations. There are no explicit
22 references within the patent claims or specifications requiring that the transverse seals be
23 “straight” or “separate.” To the contrary, because the “side edge” between the two transverse
24 seals can also be a seal, and all three edges must connect, the patent must claim a configuration
25 wherein all three seals are connected to one another, hence, not separate. The fact that the seals
26 are described as “pairs” does not necessarily mean that they cannot also connect through a side
27 edge seal; they are described as “pairs” because they form two sides of each pouch. See ‘191
28 patent at 2:6-10 (“The web has hermetically closed side edges and longitudinally spaced *pairs* of

United States District Court
Northern District of California

1 transverse seals.”) (emphasis added). They may or may not connect—there is no basis to import a
2 limitation not otherwise apparent from the claim language.

3 Although the patent summary describes the “present invention” as “pouches having four
4 inch *square* external dimensions, [such that] dunnage units are produced at the rate of eight cubic
5 feet per minute,” ‘191 Patent at 1:59-63, 2:29-31 (emphasis added), that does not necessarily
6 require the transverse seals (as opposed to the edge) to be straight. Although every patent figure in
7 the specifications shows that the seals on the web are separate and straight and form square
8 pouches, there is no intrinsic evidence to support an inference that “the patentee . . . intends for the
9 claims and the embodiments in the specifications to be strictly coextensive.” *Phillips*, 415 F.3d at
10 1323.

11 Further, although the term “transverse” could mean “[a] direction *perpendicular* to the
12 direction of working,” FPI Op. Br., Ex. R (Engineering Dictionary) at 1 (emphasis added),
13 “perpendicular” could refer merely to the general direction and orientation of the seals. It does not
14 preclude a seal that transverses from the fill edge to the opposite edge with a curved or zig-zagged
15 pattern.

16 Accordingly, the Court rejects FPI’s proposed construction. APS has not proposed a
17 competing construction so no special construction will be adopted.

18 ///
19 ///
20 ///
21 ///
22 ///
23 ///
24 ///
25 ///
26 ///
27 ///
28 ///

E. “inflating the pouches . . .” (‘459 patent only [cl. 1])

The ‘459 patent claims “[a] process of forming dunnage units from a preformed web, the process comprising: . . . inserting a guide pin into the performed pocket of the preformed web after the preformed web is formed; [and then] inflating the pouches defined by the preformed web to an inflated volume that causes edges of **the gap forming area** to spread apart between the preformed inflation side line of perforations and the preformed spaced apart opposite side line of perforations[.]” ‘459 Patent at 34-60. The parties dispute what may constitute “the gap forming area.” In particular, the patent specifications disclose three embodiments of the “gap forming area” [22], *see* ‘459 patent at 4:24-5:25, displayed in Figures 4-6, which are reproduced below:

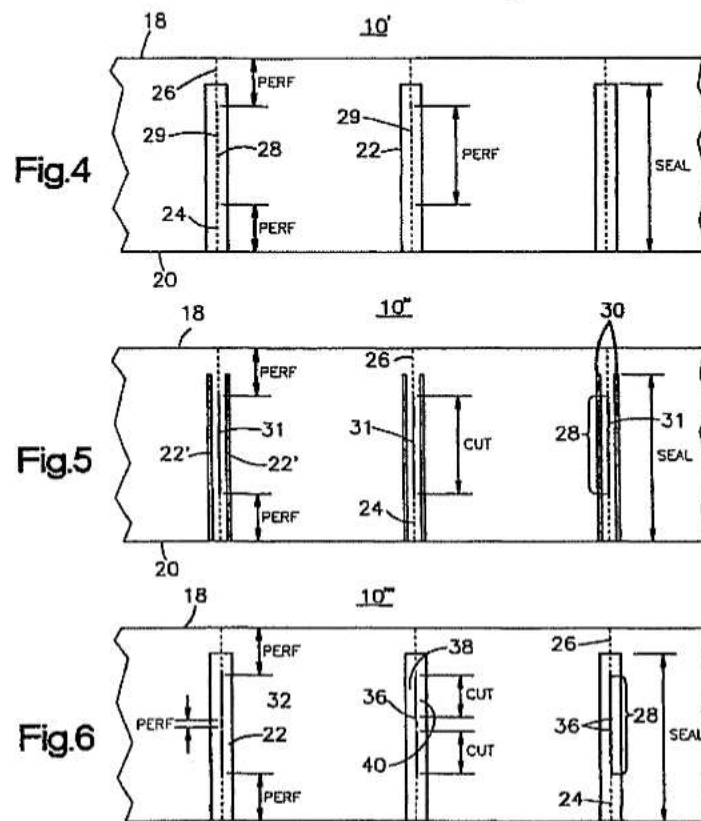

The difference is that the gap-forming area of Figure 4 “includes an easily breakable line of perforations,” the area in Figure five “comprises an elongated cut,” and the area in Figure 6 “comprises at least two elongated cuts.” *Id.*

Read broadly, the plain text of the claim language, supported by the elaboration of

1 preferred embodiments in the specification, would cover all three embodiments.

2 However, FPI proposes construing this term such that it is limited to the embodiment
3 depicted in Figure 6, wherein the gap forming area “comprises at least two elongated cuts [32]
4 separated by light connections of plastic [36] also referred to as ‘ticks,’” which “connections [36]
5 rupture or otherwise break [during inflation] resulting in a gap [13] between the spaced pairs of
6 perforations [24, 26].” *Id.* at 5:7-16. Thus, FPI proposes construing the term as meaning
7 “inflating the pouches to a volume that causes connections or ticks in the gap forming area to
8 break apart or rupture thus creating the single, uninterrupted gap forming area.”

9 FPI does not argue that the disclaimer comes from the claim language itself or the
10 specifications—it would have a hard time doing so because the language of both is broad and
11 facially includes no such limitation. The sole basis for FPI’s proposed construction is APS’s
12 purported disclaimer of the embodiments described in Figures 4-5 and limitation to the
13 embodiment in Figure 6 during the prosecution history. In particular, in the prosecution history,
14 APS summarized a conversation and agreement it reached with the Patent Examiner during
15 January 5 and 6, 2010 interviews in an amendment dated January 7, 2010. *See* FPI Op. Br., Ex. U
16 at 11. The examiner requested that APS pick only one of the gap forming areas shown in the
17 embodiments of Figures 4, 5, and 6 “for the Examiner to limit his search to.” FPI Op. Br., Ex. U
18 at 11-12. APS acquiesced, stating: “Applicant agreed to that request and hereby selects the
19 embodiment shown in Figure 6. Claims that do not read on the gap forming embodiment
20 illustrated by Figure 6 are canceled by this amendment.” FPI Op. Br., Ex. U at 11.

21 In opposition, APS relies principally on statements during prosecution history in which it
22 argued for inclusion of all three embodiments, *see* APS Op. Br., Ex. V. (dated Jul. 25, 2008); APS
23 Resp. Br., Ex. KK (dated Aug. 8, 2008); APS resp. Br., Ex. MM (dated Jun. 24, 2009), but these
24 pre-date and are superseded by the January 7, 2010 express disclaimer quoted above in which APS
25 “hereby selects the embodiment shown in Figure 6.” FPI Op. Br., Ex. U at 11.

26 APS also quotes language in its January 7, 2010 letter that “the term ‘gap forming area’ is
27 generic and reads on all of the gap forming area embodiments shown in Figures 4-6.” But that
28 language was cherry-picked and is misleading. APS omits the immediately following sentence:

1 “As requested by the Examiner during the telephone interview, Applicant has selected one of the
2 gap forming areas, namely the embodiment of Figure 6, for the Examiner to limit his search to.
3 Claims that do not read on the gap forming area of Figure 6 have been canceled by this
4 amendment. More specifically, the claims directed to the specific ‘cut’ embodiment of the gap
5 forming area, shown in Figure 5, have been canceled by this amendment.” FPI Op. Br., Ex. U at
6 11-12. The unambiguous disclaimer is evident in other portions of this document. *See id.* at 11
7 (“Claims 53, 54, 60, 65 have been canceled as requested by the examiner, as not reading on the
8 ‘gap forming area’ embodiment selected by Applicant (i.e., Figure 6) pursuant to the request by
9 the Examiner during the telephone interview described above.”). Because the limitation of the
10 claim to the embodiment in Figure 6 was clear and unmistakable, APS may not assert a broader
11 claim now. *See Biogen Idec, Inc. v. GlaxoSmithKline LLC*, 713 F.3d 1090, 1095 (Fed. Cir. 2013)
12 (“[W]hen the patentee unequivocally and unambiguously disavows a certain meaning to obtain a
13 patent, the doctrine of prosecution history disclaimer narrows the meaning of the claim consistent
14 with the scope of the claim surrendered.”); *see also Uship Intellectual Props., LLC v. U.S.*, 714
15 F.3d 1311, 1315 (Fed. Cir. 2013) (“[A] patent applicant’s response to a restriction requirement
16 may be used to interpret patent claim terms or as a source of disclaimer.”).

17 At the hearing, APS attempted to argue that the statements did not constitute a limitation or
18 disclaimer because they were merely referring to the cancelled claims. In other words, APS
19 attempted to argue that by cancelling claims that read only on the disclaimed embodiments, it did
20 not simultaneously limit the scope of the surviving claims to disclaim the same embodiments. -
21 This argument is meritless. The patent examiner clearly requested that APS choose only one of
22 the embodiments represented in Figures 4-6. APS clearly chose Figure 6. *See* FPI Op. Br., Ex. U
23 at 11-12 (“Claims that do not read on the gap forming area of Figure 6 have been canceled by this
24 amendment.”). It follows that any claims which narrowly covered only a disclaimed embodiment
25 (e.g., Figure 5) would be cancelled in their entirety. But it also follows that the surviving claims
26 which encompass the embodiment of Figure 6 and Figures 4 or 5 would not be cancelled in their
27 entirety but would be limited to the chosen embodiment, Figure 6. Based on APS’s express
28 election of only the embodiment shown in Figure 6, “a competitor would [also] reasonably

1 conclude that [APS] clearly and unmistakably limited all of the [claims],” *Uship*, 714 F.3d at
2 1316, to Figure 6—otherwise, the disclaimer requested by the patent examiner would have no
3 practical effect. Indeed, the patent examiner asked for APS to narrow its claim in order to “limit
4 his search,” FPI Op. Br., Ex. U at 11-12, and he would not have been able to do so if other claims
5 were not limited to Figure 6. Although the language of claim 1 was not amended to expressly
6 state such a limitation, the prosecution history unambiguously establishes it.

7 APS’s sole remaining argument for a broader interpretation of claim 1 of the ‘459 patent is
8 that FPI’s limitation will create redundancy between independent claim 1 and dependent claim 2,
9 which reads “The process of claim 1 wherein said gap forming area comprises weak connections
10 and wherein said weak connections break upon inflation to cause said edges of said gap forming
11 area to spread apart.” ‘459 patent at 8:3-6. APS is correct that, in other circumstances, the
12 doctrine of claim differentiation would weigh against FPI’s interpretation. However, the claim
13 differentiation doctrine does not overcome the power of APS’s unambiguous disclaimer during
14 prosecution history. *See Howmedica Osteonics Corp. v. Zimmer, Inc.*, 822 F.3d 1312, 1323 (Fed.
15 Cir. 2016) (“[C]laim differentiation is a rebuttable presumption that may be overcome by a
16 contrary construction dictated by the written description or prosecution history. . . . Claim
17 differentiation is not conclusive; it is a guide, not a rigid rule. Although it is a useful tool, claim
18 differentiation does not require that the dependent claim tail . . . wag the independent claim dog.”
19 (quotations and citations omitted)).

20 In light of the foregoing, the Court adopts FPI’s construction limiting claim 1 of the ‘459
21 patent to the embodiment depicted in Figure 6; the relevant term is construed to mean “inflating
22 the pouches to a volume that causes connections or ticks in the gap forming area to break apart or
23 rupture thus creating the single, uninterrupted gap forming area.”

24 **III. INDEFINITENESS**

25 FPI contends that three remaining terms are indefinite. Before analyzing them, the Court
26 summarizes the legal standard for indefiniteness.

27 A. Legal Standard

28 “A claim is invalid for indefiniteness if its language, when read in light of the specification

1 and the prosecution history, ‘fails to inform, with reasonable certainty, those skilled in the art
2 about the scope of the invention.’” *Biosig Instruments, Inc. v. Nautilus, Inc.*, 783 F.3d 1374, 1377
3 (Fed. Cir. 2015) (citation and alteration omitted). Indefiniteness must be proven with clear and
4 convincing evidence. *Id.* “[G]eneral principles of claim construction apply” to an allegation of
5 indefiniteness, including “consideration of primarily the intrinsic evidence, *viz.*, the claim
6 language, the specification, and the prosecution history.” *Id.* at 1378 (citations and quotations
7 omitted).

8 “When a ‘word of degree’ is used, the court must determine whether the patent provides
9 ‘some standard for measuring that degree.’” *Id.* (citation and quotation omitted). Balancing the
10 need to provide incentives for innovation and also to apprise the public of a claim’s scope, the
11 Supreme Court has held that “a patent’s claims, viewed in light of the specification and
12 prosecution history, [must] inform those skilled in the art about the scope of the invention with
13 *reasonable certainty.*” *Nautilus, Inc. v. Biosig Instruments, Inc.*, 134 S.Ct. 2120, 2124 (2014)
14 (emphasis added). This standard “mandates clarity, while recognizing that absolute precision is
15 unattainable.” *Id.* at 2129. It is not “sufficient that a court can ascribe *some* meaning to a patent’s
16 claims; the definiteness inquiry trains on the understanding of a skilled artisan at the time of the
17 patent application, not that of a court viewing matters *post hoc.*” *Id.* at 2130. “[W]hen a claim
18 limitation is defined in ‘purely functional terms,’ a determination of whether the limitation is
19 sufficiently definite is ‘highly dependent on context (*e.g.*, the disclosure in the specification and
20 the knowledge of a person of ordinary skill in the relevant art area).” 783 F.3d at 1377 (citation
21 and quotation omitted).

22 B. Analysis: “extending substantially from the side edge to the fill edge” (‘191 patent [cl. 8])

23 Claim 8 of the ‘191 patent claims “[a] plastic web for the manufacture of fluid filled units
24 comprising: . . . a plurality of longitudinally spaced transverse lines of weakness extending
25 substantially from the side edge to the fill edge.” ‘191 patent at 7:14-8:3. FPI contends that the
26 underlined phrase is indefinite. It is undisputed that the patent claims and specification do not
27 expressly define what it means to “substantially extend.”
28

1 Courts have recognized that the word “substantial” in a patent claim is a term of degree.⁴
 2 That, however, does not resolve the problem. Even a term of degree must be sufficiently definite.
 3 *See Berkheimer v. HP, Inc.*, 881 F.3d 1360, 1364 (Fed. Cir. 2018) (“Our case law is clear that the
 4 objective boundaries requirement applies to terms of degree.”).

5 APS cites only one case in which the term “substantial” was upheld as sufficiently definite.
 6 *Apple, Inc. v. Samsung Elecs. C. Ltd.*, 932 F.Supp.2d 1076, 1083 (N.D. Cal. 2013) (applying
 7 “insolubly ambiguous” standard to hold that “substantially centered” was not indefinite where
 8 skilled artisans testified that they could understand its meaning). However, that case applied the
 9 more lax standard for indefiniteness preceding *Nautilus*, and thus carries little weight here. *See Eli*
 10 *Lilly and Co. v. Teva Parenteral Medicines, Inc.*, 845 F.3d 1357, 1370, 1370 n.9 (Fed. Cir. 2017)
 11 (explaining that pre-*Nautilus* “a term was indefinite only if it was ‘not amenable to construction’
 12 or was ‘insolubly ambiguous,’” but post-*Nautilus* it is indefinite if “read in light of the
 13 specification delineating the patent, and the prosecution history, [it] fail[s] to inform, with
 14 reasonable certainty, those skilled in the art about the scope of the invention” (citations and
 15 quotations omitted)).

16 After *Nautilus*, many courts have rejected terms of degree (including “substantially”) as
 17 indefinite where the intrinsic evidence did not provide a standard for measuring the amount of
 18 degree tolerated, and extrinsic expert evidence failed to establish that a person of ordinary skill in
 19 the art would otherwise understand the term.⁵ However, the term “substantial” has been upheld

21 ⁴ *See Cordis Corp. v. Medtronic AVE, Inc.*, 339 F.3d 1352, 1360 (Fed. Cir. 2003) (district court
 22 erred in adopting narrow construction of term “substantially uniform thickness” because no
 23 unambiguous disclaimer– no consideration of indefiniteness); *Playtex Prods. Inc. v. Procter &*
 24 *Gamble Co.*, 400 F.3d 901, 909 (Fed. Cir. 2005) (district court erred in construing “substantially
 25 flattened surfaces” to mean “something flat in practice” where intrinsic evidence did not support
 that limitation); *Liquid Dynamics Corp. v. Vaughan Co.*, 355 F.3d 1361, 1368 (Fed. Cir. 2004)
 (district court erroneously added limitation unsupported by intrinsic record where it construed
 “substantial helical flow” to mean a perfectly helical flow).

26 ⁵ *See Core Wireless Licensing S.A.R.L. v. Apple Inc.*, Case No. 15-cv-05008-PSG, 2016 WL
 27 3124614, at *12 (N.D. Cal. Jun. 3, 2016) (holding that the term “substantially impair the quality of
 28 the user information” was indefinite where the specification left “a ‘zone of uncertainty’”
 regarding the number of stolen speech frames that would impair the quality of information);
Effective Exploration, LLC v. Bluestone Nat. Res. II, LLC, 2017 WL 3193322, at * 22 (E.D. Tex.
 July 27, 2017) (term “extend in substantially opposite directions” held indefinite); *Fiber, LLC v.*

1 where the claim and specification language provided objective boundaries. *See Exmark*
 2 *Manufacturing Co. Inc. v. Briggs & Stratton Power Prods. Grp., LLC*, 879 F.3d 1332, 1346 (Fed.
 3 Cir. 2018) (holding that the term “substantially straight” to describe component in patent for
 4 lawnmower design was sufficiently definite where the patent specification made clear that
 5 component “must be sufficiently straight to connect [two parts the device]” and to perform the
 6 function of deflecting grass cuttings from each blade into the direction of the next blade).

7 Although Dr. Singh makes a number of unpersuasive arguments in support of APS,⁶ the
 8 Court need only focus on the one that sticks: that the patents “disclose that one purpose of the
 9 ‘transverse lines of weakness’ is to allow separation of the dunnage units from each other after
 10 inflation and sealing.” Singh Decl. ¶ 93 (APS Op. Br., Ex. U). The patent specification in fact
 11 provides that “[t]he pouches are separable along the transverse lines [of weakness] 36.” ‘191
 12 Patent at 3:55-56; *see also* ‘288 Patent at 3:55-56. Although APS did not explicitly brief this
 13 argument, Dr. Singh’s reference to purpose is akin to an assertion that this claim language is

14
 15 *Ciena Corp.*, 2017 WL 3896443, at *12-13 (D. Colo. Sep. 6, 2017) (term “substantially complete
 16 set” held indefinite where “[t]here is nothing in the specification that clarifies what portion of a
 17 ‘complete set’ would be a ‘substantially complete set,’” as it could be a majority or at least one);
 18 *Fairfield Indus., Inc. v. Wireless Seismic, Inc.*, 2015 WL 1034275, at *16 (S.D. Tex. Mar. 10,
 19 2015) (holding term “substantially prevent communication interference” to be indefinite where
 20 “the specification and prosecution history lack evidence that would inform a person skilled in the
 21 art as to how much interference prevention the patent contemplates sets it apart from patents that
 22 have overcome indefiniteness challenges”). *Cf. Berkheimer*, 881 F.3d at 1361-64 (the term
 23 “minimal redundancy” was indefinite where intrinsic evidence “contains no point of comparison
 24 for skilled artisans to determine an objective boundary of ‘minimal’” and expert provided
 25 uncontested testimony that a person of ordinary skill in the art would not understand); *In re*
 26 *Walter*, 698 F. App’x 1022, 1026 (Fed. Cir. 2017) (holding that the term “block-like” was
 27 indefinite because it “is a term of degree without any accompanying guidance in the intrinsic
 28 record for determining its scope;” and even though it “ostensibly covers a range of shapes that are
 sufficiently ‘like’ a ‘block’ and excludes those that are not,” “nothing in the intrinsic record offers
 ‘objective boundaries’ for ascertaining whether a given shape falls into either category,” and
 expert failed to provide evidence supporting his opinion that it was a term of art in structural
 engineering field).

6 Dr. Singh’s claim that “substantially” means “largely” but not “wholly” simply replaces one
 term of degree with two, without providing definiteness. *See* Singh Decl. ¶ 21 (APS Resp. Br. Ex.
 NN). His later assertion that that “substantially” means 50% to 100% is drawn from whole cloth
 with no basis in the claim language or patent specification. *Id.* ¶ 23. Moreover, it contradicts Dr.
 Singh’s own testimony. He testified that the patent did not disclose a mathematical range. *See*
 Singh Dep. at 179:6-20 (FPI Op. Br. Ex. J). Further, when asked whether extending 30%, 80%, or
 90% would be considered “substantial,” he could not answer. *Id.* at 180:21-181:20. If
 “substantially” would really be understood by a skilled artisan to mean “50-100%,” then he should
 have been able to answer no to 30% and yes to 80% and 90%.

1 defined in “functional” terms, thereby saving it from indefiniteness. For example, in *Biosig*
 2 *Instruments*, the Federal Circuit held that a patent claim was not indefinite where it provided for a
 3 “spaced relationship” between two electrodes in a heart-rate monitor, because it provided two
 4 objective standards that a skilled artisan would have understood: first, the space could not be
 5 infinitesimal such that the electrodes collapsed into one, nor could it be wider than a hand because
 6 the claim required independent detection of signals at two points of a hand; and, second, the claim
 7 described the function of the spaced relationship to be the substantial removal of EMG signals
 8 between the electrodes, and a skilled artisan could apply a test to determine the “spaced
 9 relationship” at which the EMG signals would be removed. 783 F.3d at 1382-84.

10 Similarly, here, the function of the transverse line of weakness is to permit facile
 11 separation of the pouches. Moreover, it is obvious that the lines of weakness must have a length
 12 that is greater than zero but no longer than the web itself. As in *Biosig Instruments*, the range of
 13 possible lengths is finite and a skilled artisan could test how far the transverse lines of weakness
 14 must extend in order to permit facile separation of the pouches. *See also Exmark*, 879 F.3d at
 15 1346 (term “substantially straight” not indefinite where given meaning with reasonable certainty
 16 based on function of component). Mathematical precision here is unnecessary because the
 17 function of permitting facile separation of pouches depends in part upon *e.g.* the tensile strength
 18 and thickness of the web material. The functional approach is reasonable and perhaps even
 19 unavoidable. Accordingly, the Court denies FPS’s request to hold the term indefinite.

20 C. Analysis: “the gap is sized to permit insertion of a separating device” (‘994 patent cl. 1)

21 The ‘994 patent claims:

22 [a]n inflated dunnage unit array, comprising: at least one row of
 23 interconnected inflated pouches, . . . wherein each inflation edge
 24 line of perforations and corresponding opposite edge line of
 25 perforations are spaced apart by a continuous gap through the first
 26 and second layers that extends from the inflation side line of
 27 perforations to the opposite side line of perforations, wherein said
gap forms as said side edges of adjacent pouches move away from
one another during inflation, wherein the gap is sized to permit
insertion of a separating device through the first and second layers
between each pair of interconnected dunnage units.

28 ‘994 patent, claim 1 at 7:33-8:8 (emphasis added). Dependent claim 2 claims “[t]he dunnage unit

1 array of claim 1 wherein the gap is sized to permit insertion of a human hand.” *Id.* at 8:9-10.

2 FPI contends that the term “sized to permit insertion of a separating device” in claim 1 is
3 indefinite. FPI’s attack is based on the notion that the patent gives no objective boundaries for the
4 size of a “separating device” and thus no boundaries for the size of the “gap.”

5 Neither the claims nor the patent specification identify a “separating device.” Indeed, the
6 only mechanism specifically identified is a human hand. *See* ‘994 Patent at 1:64-66 (in summary,
7 explaining that “[i]n the present invention, to separate adjacent dunnage units, a worker simply
8 inserts a hand or hands into the gap . . .”); *id.* at 2:22-26 (“The inflation edge line of perforations
9 and the opposite edge line of perforations are spaced apart by a gap that allows a worker to insert
10 an object, such as a hand, to easily separate the pair of adjacent inflated dunnage units.”); *id.* at
11 3:51-54 (“To separate a pair of adjacent dunnage units 12, a worker simply inserts an object or
12 objects, such as a hand or hands, into the gap”); *id.* at 5:38-40 (in specification re: Fig. 3,
13 stating “To separate a pair of adjacent units 12’, a worker inserts an object such as the worker’s
14 hand or hands into the gap 13.”).

15 Though the size of a human hand would be known to a skilled artisan, it cannot give
16 definiteness to claim 1 because dependent claim 2 explicitly invokes the human hand. *See* ‘994
17 patent at 8:9-10 (claiming “[t]he dunnage unit array of claim 1 wherein the gap is sized to permit
18 insertion of a human hand”). The doctrine of claim differentiation thus suggests that claim 1 must
19 be construed to concern a “separating device” other than a human hand; indeed, the claim
20 language itself supports that construction. *See Augme Techs., Inc. v. Yahoo! Inc.*, 755 F.3d 1326,
21 1333 (Fed. Cir. 2014) (“Different claim terms are presumed to have different meanings.”). No
22 other separating device is identified in the intrinsic evidence. Nor was APS’s expert able to
23 identify how a person of ordinary skill in the art would know the device or its size. *See Singh*
24 *Depo.* (FPI Op. Br. Ex. J) at 201:11-202:12 (stating that “separating device” refers to a
25 “mechanical system or machine” but agreeing that nothing specifies its size).

26 Furthermore, Dr. Singh concedes that one could not know the size of the gap of claim 1
27 without knowing the size of the inserting device. *Id.* at 207:7-11. He simply asserts, however,
28 that one of ordinary skill in the art “and even a layperson” would know the “objective

1 boundaries,” but he does not explain how or why. Singh Decl. (APS Op. Br. Ex. U) ¶¶ 131-132.
 2 And although he asserts one of ordinary skill would know that the separating device could not be
 3 as small as a needle to avoid puncturing the pouches nor as big as a baseball bat to avoid crushing
 4 them (the examples raised by FPI’s expert, Dr. Schueneman), Singh Decl. (APS Resp. Br. Ex.
 5 NN) ¶¶ 64-70, these two extreme examples do not indicate that one of ordinary skill would know
 6 what *does* fall within the scope of the patent claims. Dr. Singh does not identify any particular
 7 commonly used separating device, for example, that one of ordinary skill would immediately think
 8 would apply when interpreting the claim. To the contrary, Dr. Schueneman’s testimony that one
 9 of ordinary skill would not know how large the separating device and hence how large the gap
 10 would be without some objective guidance is more persuasive. *See* Schueneman Decl. (FPI Op.
 11 Br. Ex. H) ¶¶ 55-56, 58.

12 There is absolutely no intrinsic evidence in the Gap-Forming patents about what the
 13 separating devices could be. When asked at the hearing, APS’s counsel referred the Court to
 14 Figure 1 in the ‘191 patent—one of the Variable Perforation patents which do not describe webs
 15 with gaps. That figure is irrelevant to the Gap Forming patents. Moreover, the separating device
 16 identified [76] illustrates the manner in which *two strings of pouches* are separated from one
 17 another in the Variable Perforation Patents, *not* a separating device for *adjacent* pouches in the
 18 same string of pouches as claimed by the Gap-Forming Patents, as shown below:

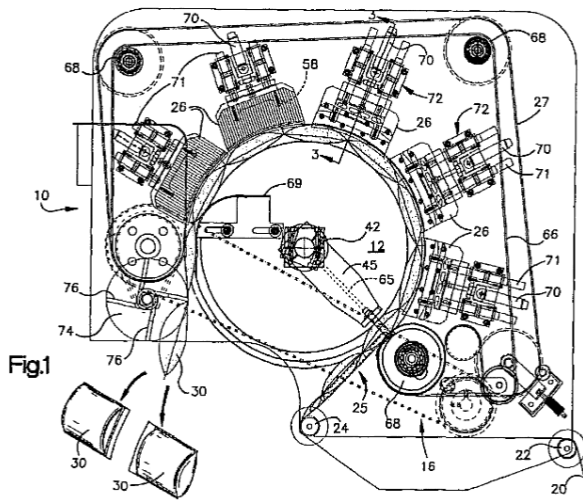

United States District Court
Northern District of California

1 Counsel’s errant example merely underscored the absence of any objective guidance
2 within the Gap Forming patents themselves. There are no intrinsic figures illustrating a separating
3 device and, even if there were, “patent drawings do not define the precise proportions of the
4 elements and may not be relied on to show particular sizes if the specification is completely silent
5 on the issue.” *Hockerson Halberstadt, Inc. v. Avia Grp. Int’l, Inc.*, 222 F.3d 951, 956 (Fed. Cir.
6 2000).

7 Accordingly, the Court concludes that claim 1 is indefinite with respect to the term “the
8 gap is sized to permit insertion of a separating device.”

9 D. “Large Perforations” (‘288 patent, cl. 8)

10 FPI also challenges the term “large perforations” as it appears in claim 8 of the ‘288 patent
11 as indefinite. Claim 8 is dependent on independent claim 7. Both claims are reproduced below.

12 **Claim 7 of ‘288 Patent**

Claim 8 of ‘288 Patent

13 A plastic web for the manufacture of fluid filled units comprising:

- 14 Elongate flattened top and bottom layers;
- 15 The layers being longitudinally joined at a side edge by a selected one of a fold and a seal;
- 16 Longitudinally spaced transverse seals, the seals extending from the side edge toward but spaced from a split edge of the layers;

17 A plurality of longitudinally spaced transverse lines of weakness extending away
18 from the side edge toward the split edge;
19 wherein the transverse lines of weakness comprise perforations including relatively short perforations extending away from the split edge toward the side edge and longer perforations that extend away from the short perforations toward the side edge.

The web of claim 7 wherein there are spaced sets of large perforations with the sets respectively solely in an associated transverse seal.

20 FPI contends that there is no intrinsic evidence providing definiteness to the meaning of
21 “large perforations” in claim 8. The Court disagrees. Claim 8 is dependent on claim 7. “Large
22 perforations” in dependent claim 8 is reasonably understood to refer to the “longer perforations” in
23 independent claim 7. The key distinction between the two claims is that in claim 8, the “large
24 perforations” (*i.e.*, the “longer perforations” from independent claim 7) are located “solely in an
25
26
27
28

1 associated transverse seal.”⁷

2 The specification confirms that the key point is that the perforations get longer the further
3 away they extend from the longitudinal line, as illustrated in Figures 7 and 8 of the ‘288 patent:

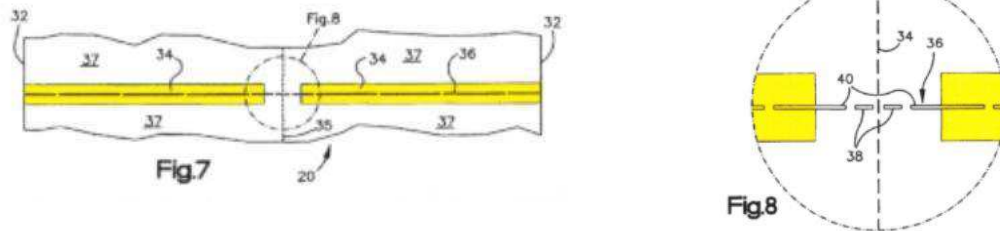

12 According to the specification, “[t]he perforations of the transverse lines [36], in a further
13 contrast with the perforations of the longitudinal lines [35], are not of uniform dimension
14 longitudinally of the lines. Rather, as is best seen in Fig. 8, a pair of small or short perforations
15 [38] is provided in each line. The small perforations [38] of each pair are disposed on opposite
16 sides of and closely spaced from the longitudinal lines [34]. Each transverse line of weakness also
17 includes a pair of intermediate length perforations [40] which are spaced and positioned on
18 opposite sides of the small perforations [38]. The intermediate perforations extend from unsealed
19 portions of the superposed layers into the respective seals of the associated transverse seal pair.
20 The remaining perforations of each line are longer than the intermediate perforations [40].” ‘288
at 3:59-4:5.

21 Although “large,” “longer,” and “small” are all terms of degree, that does not defeat
22 definiteness here. The specification discloses that the function of the varying relative lengths of
23 the perforation on the transverse perforations is to ensure that the adjacent pouches remain intact
24

25
26
27
28

7 For this reason, FPI’s argument that “large perforations” in claim 8 should be presumed to have a different meaning than “longer perforations” in claim 7 fails. See *Chi. Bd. Options Exch., Inc. v. Int’l Sec. Exch., LLC*, 677 F.3d 1361, 1369 (Fed. Cir. 2012) (courts apply a “general presumption that different terms have different meanings”). However, claim 8 is distinguished from claim 7 by the exclusive placement of large perforations within the seals, not by the use of “large perforations” in claim 8 distinct from “longer perforations” in claim 7.

United States District Court
Northern District of California

1 even as the longitudinal transverse line of weakness [34] is separated by the nozzle as the web
 2 slides over the machine: “[t]he web portions at opposite ends of the small perforations [38] are of
 3 sufficient size and strength to avoid a longitudinal split of the web as the web is fed over the
 4 nozzle.” ‘288 Patent at 5:48-50. Thus, as in *Biosig Instruments* and *Exmark*, discussed above, one
 5 would have to size the perforations such that the smallest ones were strong enough to withstand
 6 the force of being slid past the nozzle without breaking, while the larger ones were long enough to
 7 permit facile separation of the pouches. The appropriate size could be determined through testing.
 8 Mathematical precision is not required so long as the function is achieved. Indeed, as noted
 9 above, greater precision may not be possible in light of variations in the manufacturing process
 10 (e.g., the use of different materials to create the film).

11 Considering the ‘288 patent’s intrinsic evidence—particularly the claim language,
 12 specification, and included figures—the use of the term “large perforations” does not “depend[]
 13 ‘on the unpredictable vagaries of any one person’s opinion.’” *Interval Licensing*, 766 F.3d at
 14 1371. Rather, the patent provides “reasonable certainty” about the scope of the invention.
 15 *Nautilus*, 134 S.Ct. at 2124. FPI’s request to find the term is indefinite is denied.⁸

16 **IV. CONCLUSION**

17 In sum, the Court construes the terms as follows:

<u>Term</u>	<u>Construction</u>
“edge”	“the line at which a film surface terminates”
“fill edge”	“edge located between the two oppositely oriented strings of pouches through which each dunnage unit is filled”
“fill opening at [its/a] fourth side”	“opening located on the edge located between the two oppositely oriented strings of pouches through which each dunnage unit is filled”
“split edge”	“edge located between the two oppositely oriented strings of pouches through which each dunnage unit is filled and which splits

26 _____
 27 8 APS’s objection that FPI’s supplemental brief constitutes an improper motion for summary
 28 judgment is groundless. FPI makes no such request. It is APS’s brief which improperly exceeded
 the scope of the Court’s order on supplemental briefing by raising argument and issues irrelevant
 to the claim term at hand, such as further argument on the question whether the ‘288 patent claims
 only two strings of pouches or also single strings. See APS Response to FPI Supp. Br. at 3:7-15.

United States District Court
Northern District of California

1
2
3
4
5
6
7
8
9
10
11
12
13
14
15
16
17
18
19
20
21
22
23
24
25
26
27
28

<u>Term</u>	<u>Construction</u>
	during the inflation process”
“connected together at an inflation edge and an opposite edge”	“the layers meet and begin, and meet and terminate at two edges of the film”
“connected together at the opposite edges,” “[connected] together at their inflation edges,” “[sealed] together at their opposite edges,” and “the layers being [imperforately] joined together at a side edge”	“the layers meet and terminate at an edge of the film”
“longitudinally spaced [pairs of] transverse seals” and “transverse seals”	No construction
“inflating the pouches defined by the performed web to an inflated volume that causes edges of the gap forming area to spread apart between the preformed inflation side line of perforations and the preformed spaced apart opposite side line of perforations” [‘459 patent only]	“inflating the pouches to a volume that causes connections or ticks in the gap forming area to break apart or rupture thus creating the single, uninterrupted gap forming area”
“extending substantially from the side edge to the fill edge”	Not indefinite
“the gap is sized to permit insertion of a separating device”	Indefinite
“large perforations”	Not indefinite

This order disposes of Docket Nos. 91 and 92.

IT IS SO ORDERED.

Dated: August 2, 2018

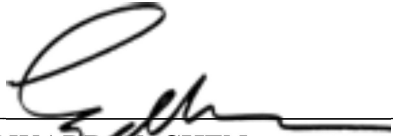

 EDWARD M. CHEN
 United States District Judge